

# VMC SCHOOL

*We protect  
our future*

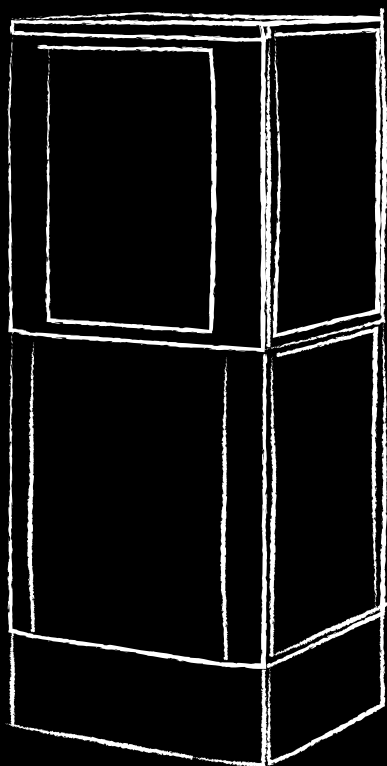

the future  
begins  
in classrooms

# Investing in School Well-being

In the universe of education, the key to building a prosperous future also lies in the well-being of students. Every investment that we make in improving school environments is a testament to our commitment to a better tomorrow. We will guide you through the opportunity offered by VMC SCHOOL to transform school classrooms into optimised learning laboratories. We will discover how together, we can rewrite the future of education starting from the quality of the most basic action:

**the breath.**

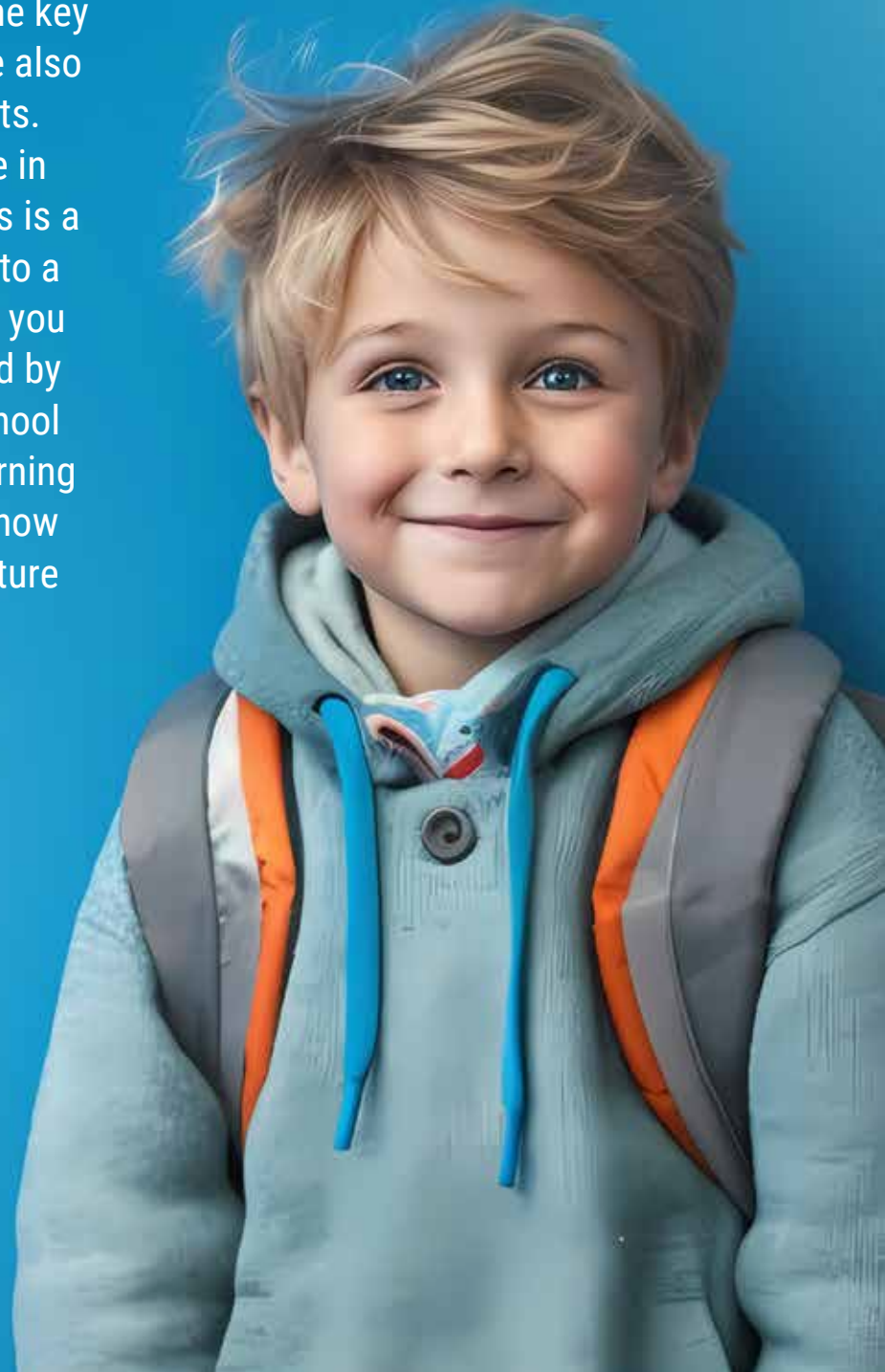



# THE CHALLENGES IN A SCHOOL ENVIRONMENT

In our classrooms, where the future is formed every day, there are invisible challenges that undermine the learning environment. These challenges often go unnoticed, but their impact is palpable and significant. Let's take a closer look at the problems related to air in classrooms.

# AIR PROBLEMS IN CLASSROOMS



## **Anidride carbonica (CO<sub>2</sub>) e la perdita di attenzione**

In a crowded environment without adequate air exchange, carbon dioxide (CO<sub>2</sub>) levels can rise rapidly. This phenomenon not only makes the air less breathable, but can also lead to a decrease in students' attention, hindering their learning.



## **Unpleasant Odours and Trapped Smog**

Without proper ventilation, unpleasant odours can proliferate in classrooms. In addition, smog from the outside can get trapped inside, compromising air quality and learning experience.



## **Waste of Energy**

The absence of an efficient ventilation system and the need to open windows frequently to ensure air exchange generate a significant waste of energy. This not only affects the environment, but also increases the operating costs of schools.



## **Contagion from Viruses and Bacteria**

In a world where public health is paramount, the school environment must be carefully considered. Lack of adequate ventilation can increase the risk of infection from viruses and bacteria, endangering the health of students and school staff.

These challenges push us to seek innovative solutions to improve air quality in classrooms. “VMC SCHOOL” is the answer to these challenges - a bold step towards a healthier and more productive school environment.



# THE SOLUTION: CLASSROOMS WITH VMC

Our commitment to addressing the challenges of the air in classrooms has led us to an innovative and indispensable solution: the introduction of VMC SCHOOL. The VMC is an advanced technology that ensures adequate air exchange in confined spaces such as classrooms, precisely controlling the supply of fresh air and the exhaustion of stale air, ensuring an always optimal environment.

Clear Advantages in the Classroom. The installation of “VMC SCHOOL” translates into tangible advantages within the classrooms.

# ADVANTAGES IN THE CLASSROOM



## Quality Learning

Thanks to the VMC, CO<sub>2</sub> levels are drastically lowered, promoting an environment in which students can concentrate better and achieve higher learning outcomes.



## Clean and Healthy Air

VMC filters the air, effectively removing pollutants and allergic substances, improving the respiratory health of students and staff.



## Safe and Clean Environment

By detecting and removing fine dust and bacterial charge from the outside air, the VMC helps maintain a clean and safe learning environment.



## Energy Saving

VMC SCHOOL solutions are designed to maximise energy efficiency, reducing schools' operating costs and their environmental impact.



## Compliance with REHVA Guidelines against COVID-19

VMC SCHOOL strictly respects the guidelines established by REHVA, contributing significantly to the prevention of the spread of viruses, including COVID-19, through controlled mechanical ventilation.

Investing in VMC is a key step to ensure a high-quality learning environment, promote student and staff health, save energy and adhere to strict health standards. "VMC SCHOOL" is the complete solution for a better future school.



# VMCS70SH

VMCS70SH is the innovative solution designed to radically transform the learning environment in classrooms. VMCS70SH is a system developed by Broferpura with the aim of ensuring maximum air quality in classrooms, creating an ideal environment for learning. VMCS70SH stands as a pillar to ensure these optimal conditions. Let's take a closer look at how VMCS70SH can improve the future of classrooms and promote the well-being of students and staff.



## DESCRIPTION

---

**HIGHLY EFFICIENT DECENTRALISED DOMESTIC HEAT RECOVERY UNIT  
WIRELESS PLUG AND PLAY SETUP INCLUDED  
AUTOMATIC BY-PASS INCLUDED**

**Heat recovery unit:** countercurrent entirely made of plastic material.

**Structure:** self-supporting EPS seal with external steel shell complete with filter extraction system and condensate drainage.

**Fans:** plug fans with EC Brushless motors.

**Filters:** the units are equipped as standard with corrugated filter cells in synthetic fibre class G4, in option F7 efficiency filter on outdoor air.

**Soundproofed plenum for air distribution and diffusion.**

**Optional:** CO<sub>2</sub> control (CO2RF). F7 efficiency filter (FTRSV48). Modbus communication module (MODBUSRF). Version with antipic heat exchanger.

## TECHNICAL SPECIFICATIONS

---

Air flow renewal	600 mc/h
Air flow extraction	600 mc/h
Thermal recovery efficiency *	90 %
Air filtration renewal	(F7) ISO e PM1 > 65 %
Air exhaustion renewal	(G4) ISO COARSE > 65 %
CO <sub>2</sub> control	Optional

\* (UNI EN 308) air renewal: 5°C 72% UR/air exhaustion: 25°C 28% RH

## SOUND POWER MEASURED AT 5 METRES

---

Frequency	Low speed	Average speed	High speed
Hz	dB	dB	dB
125	22,3	28,8	32,3
250	22,7	28,5	31,9
500	12	20,7	28,9
1000	7,4	18,8	25
2000	4,4	16,1	21,7
4000	-	8,5	14,5
8000	-	4,9	11,6
Totale	20,2 dB(A)	29,6 dB(A)	34,7 dB(A)

Certified data in Accredia's accredited Independent Laboratory

NORMATIVE REFERENCES  
ISO 11203: 1995  
EN ISO 37HI: 2010  
EN 13141-8: 2014

## DRAWINGS

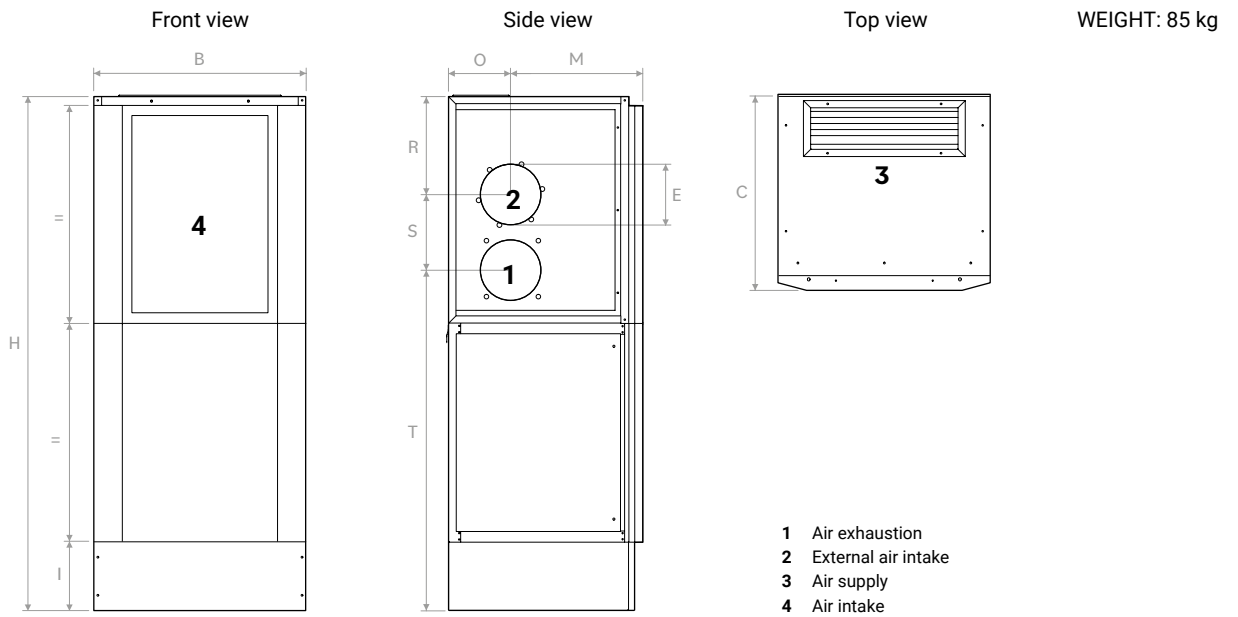

Su richiesta versione con attacchi di presa aria esterna ed espulsione posteriori.

	B	C	H	ØE	I	M	O	R	S	T
mm	702	642	1700	200	228	437	205	324	250	1126

## CLASSROOM WITH VMCS70SH UP TO 20 STUDENTS

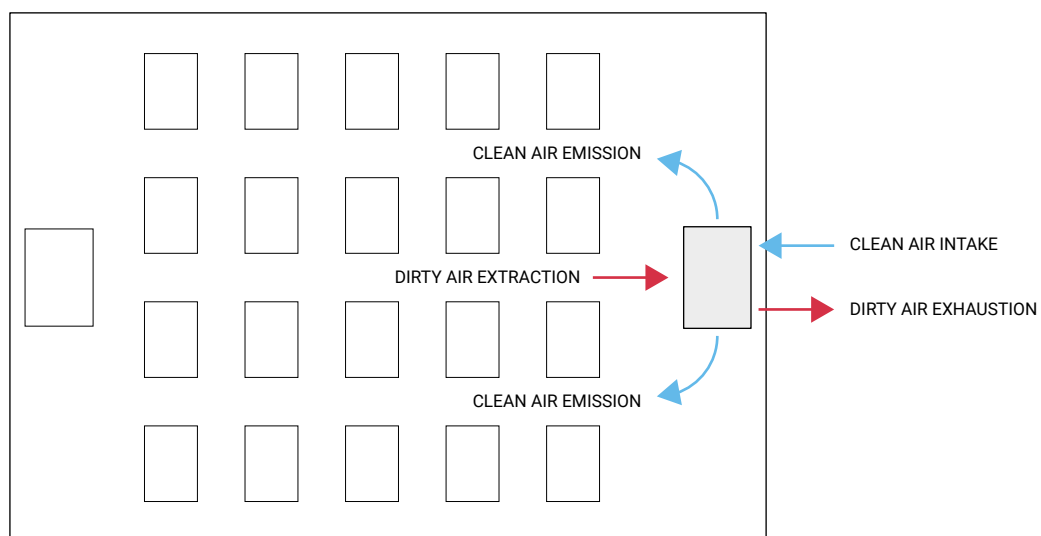

# PLUS FOR THE INSTALLATION

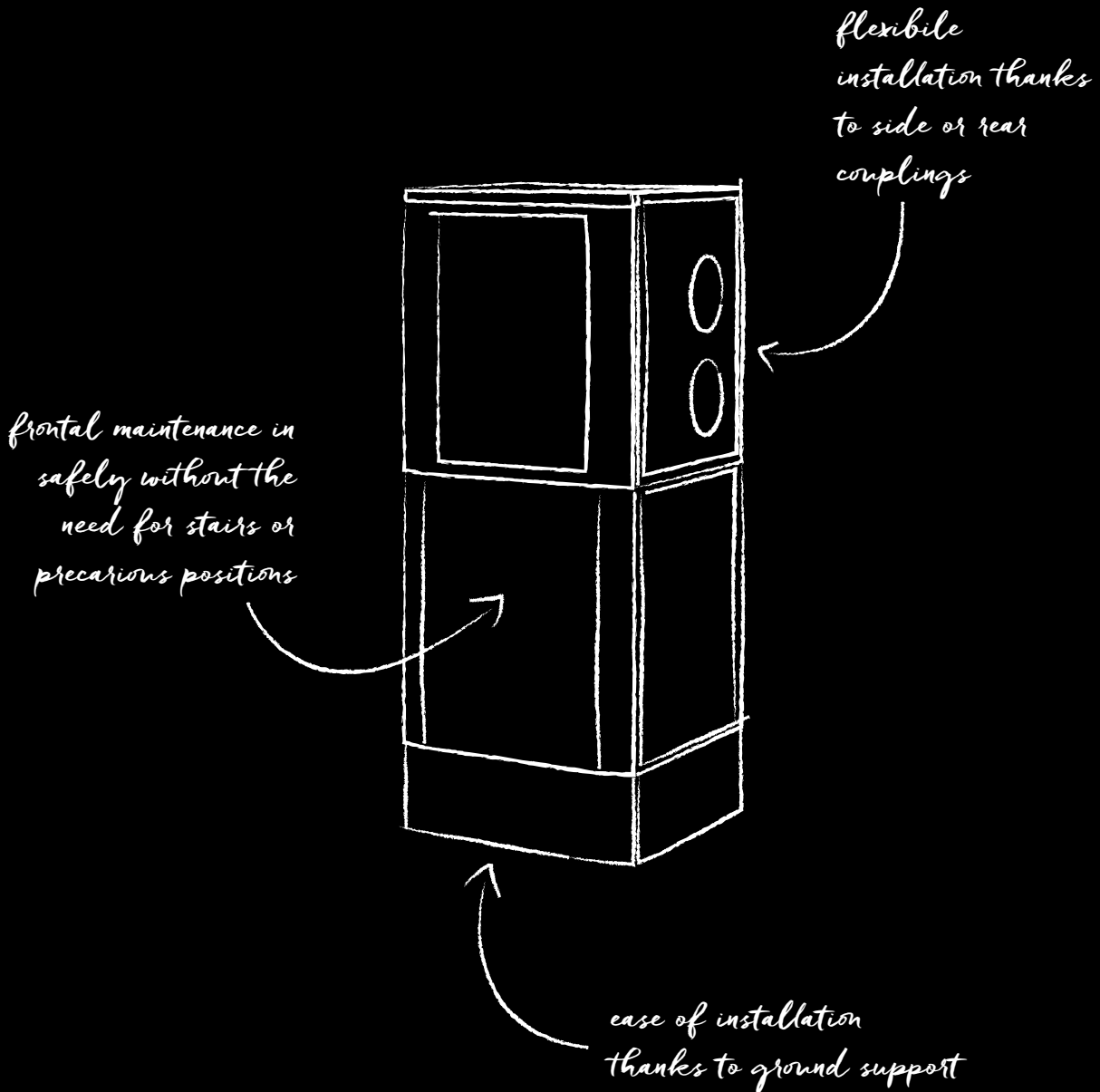



**brofer**

**BROFER srl**  
Via Roma, 66  
31023 Resana (TV) Italy  
Tel. +39 0423 716611  
Fax +39 0423 716612  
info@brofer.it

**Milan branch**  
Via E. De Amicis, 59  
20092 Cinisello Balsamo (MI)  
Tel. +39 02 66017390  
Fax +39 02 66041257  
ordinimi@brofer.it

**Naples branch**  
**JANNONE DST SRL**  
Via dei Platani  
Angolo Via Palazziello sn  
80040 z.i. PIP Sebeto VOLLA (NA)  
Tel. +39 081 19330200  
Fax +39 081 19330203  
info@jannonedst.it