

RDCD25SKHCE

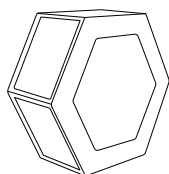

Incluido - Intercambiador entálpico
Included - Enthalpic heat exchanger

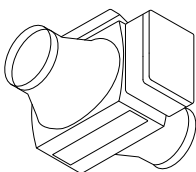

Optional - ECOFILTR PLUS

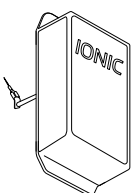

Optional - IONIC

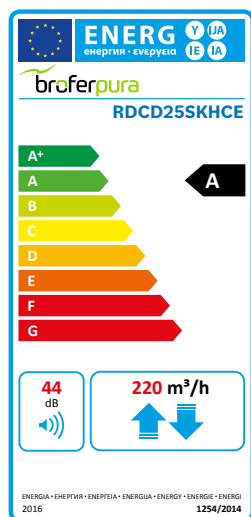

UNIDAD DOMÉSTICA DE RECUPERACIÓN DEL CALOR CENTRALIZADA DE EFICIENCIA MUY ALTA AJUSTE PLUG AND PLAY INALÁMBRICO INCLUIDO BY-PASS AUTOMÁTICO INCLUIDO INSTALACIÓN HORIZONTAL - VERTICAL - DERECHA - IZQUIERDA

Recuperador del calor: conectorriente totalmente realizado en material plástico.
Versión con intercambiador entálpico.

Estructura: autoportante de PPE con sellado completo y con sistema de extracción. Carcasa exterior de chapa prepintada con aislamiento acústico.

Ventiladores: plug fan con motor EC sin escobillas de aspiración simple.

Filtros: las unidades vienen equipadas de serie con celdas filtrantes onduladas de fibra sintética de tipo G4, con opción de filtro de eficiencia F7 en aire exterior.

DOMESTIC CENTRALIZED HEAT RECOVERY UNIT WITH VERY HIGH EFFICIENCY AND WITH WIRELESS PLUG AND PLAY CONTROL SYSTEM INCLUDED AUTOMATIC BY-PASS INCLUDED INSTALLATION HORIZONTAL-VERTICAL-RIGHT -LEFT

Heat recovery: heat exchanger of the type in countercurrent entirely made of plastic material. *Versión with enthalpic heat exchanger.*

Structure: free standing EPP seal, complete of filters ex traction system. External casing made by prepainted steel with sound proof insulation.

Fans: plug fan with EC Brushless engine single inlet.

Filters: the units are equipped with standard filter cells synthetic fiber efficiency G4, optional F7 efficiency on fresh air.

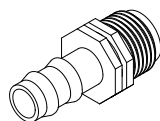

Preinstalación para el drenaje de condensación.
Predisposition for condensate drying.

Caudal de aire (m ³ / h) Nominal air flow (mc/h)	220
Presión estática útil (pa) Useful static pressure (pa)	100

DATOS POR CADA VENTILADOR | DATA FOR EACH FAN

Potencia nominal (W) Installed power (W)	50
Revoluciones (1/ min) Round (1/MIN)	4320
I nominal (A) Current (A)	0,46
Tensión (V) Rated voltage (V)	230
Frecuencia (Hz) Frequency (HZ)	50
Velocidad (n.º) Speed (nr)	3+(1 booster)

FILTROS | FILTERS

Eficiencia Efficiency Standard	G4 ISO COARSE > 65 %
Eficiencia Efficiency Optional	F7 ISO e PM1 > 65 %



DISEÑOS | DRAWINGS

PESO | WEIGHT: 30 kg

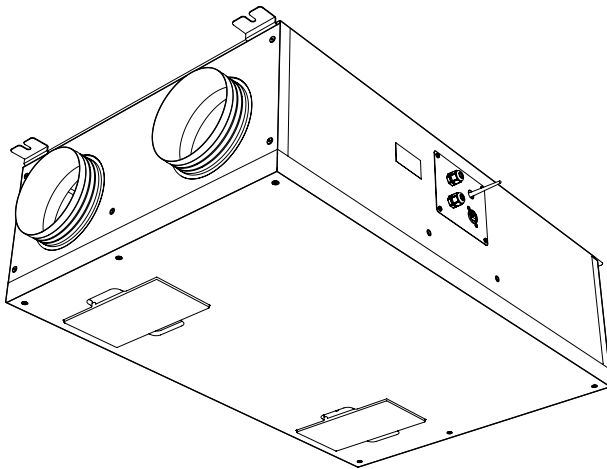

Vista desde abajo | Bottom View

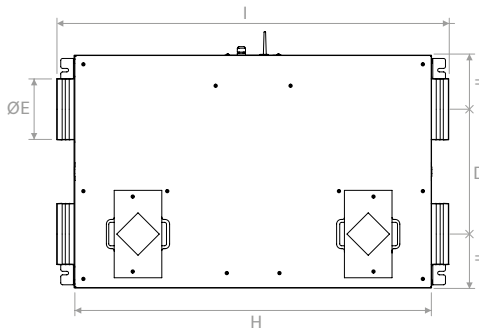

Vista interior | Internal view

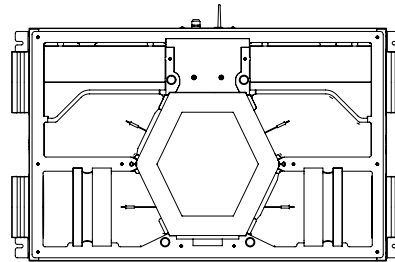

Vista lateral | Side view

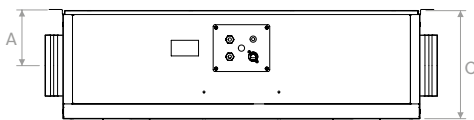

Vista frontal | Front view

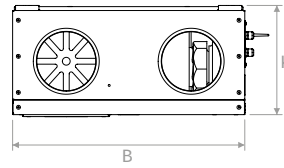

Vista de plano | Plan view

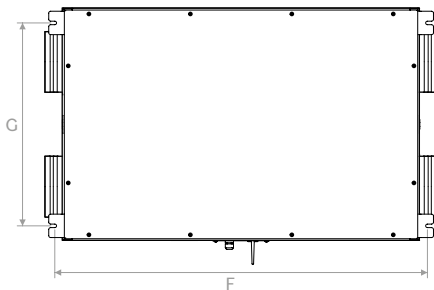

	A	B	C	D	ØE	F	G	H	I	K
mm	135	595	277	320	156	955	520	914	1005	282



PRESTACIONES CERTIFICADAS EN 13141:7:2011 | PERFORMANCE EN 13141:7:2011 CERTIFIED

Presión estática útil
Useful static pressure
① ③

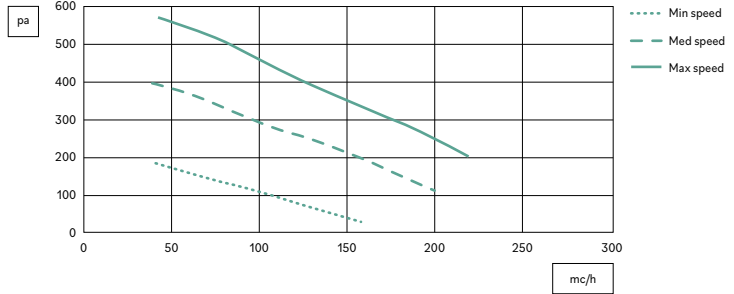

Potencia específica del ventilador
S.F.P.
②



Diagrama de eficiencia sensible en invierno
Aire exterior: 25 °C
Aire ambiente: 5 °C
Winter sensible efficiency chart
Fresh air: 25 °C
Return air: 5 °C



Diagrama de eficiencia latente en invierno
Aire exterior: 5 °C - 79 % de HR
Aire ambiente: 25 °C - 50 % de HR
Winter latent efficiency chart
Fresh air: 5 °C - 79 % R.H.
Return air: 25 °C - 50 % R.H.

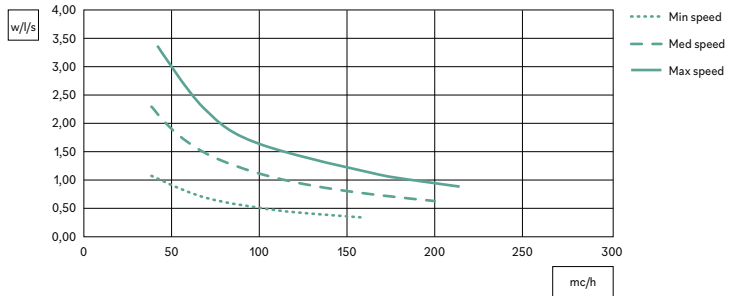

① Datos con filtros G4 estándar | Data with standard G4 filters
 ② Datos por cada ventilador | Data for single fan
 ③ Pérdidas de carga del filtro de eficiencia F7 80 pa con el máximo caudal y con filtro limpio
 Air pressure drop with F7 efficiency filter 80 pa at maximum air flow rate with clean filter

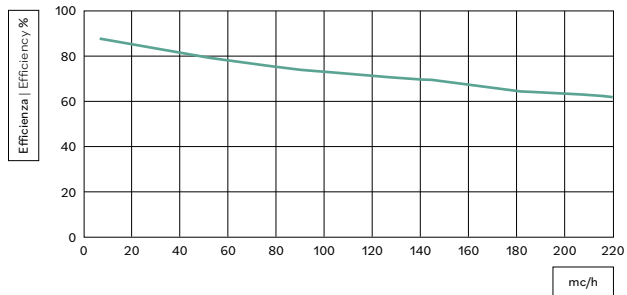
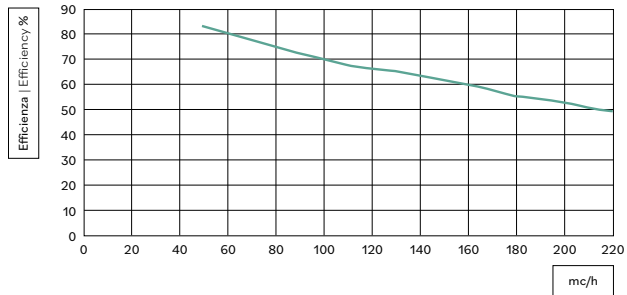

Diagrama de eficiencia sensible en verano

Aire exterior: 35 °C

Aire ambiente: 25 °C

Summer sensible efficiency chart

Fresh air: 35 °C

Return air: 25 °C



Diagrama de eficiencia latente en verano

Aire exterior: 35 °C - 57 % de HR

Aire ambiente: 25 °C - 50 % de HR

Summer latent efficiency chart

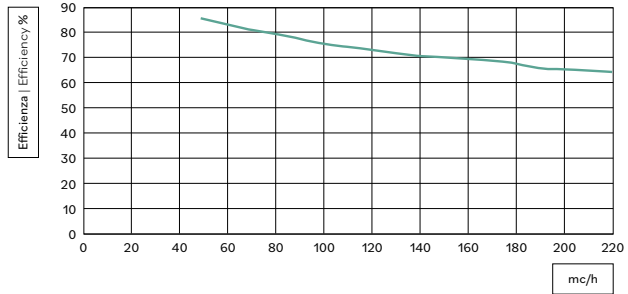
Fresh air: 35 °C - 57 % R.H.

Return air: 25 °C - 50 % R.H.

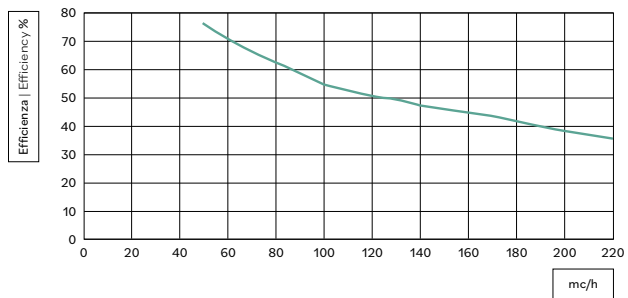

RDCD25SKHCE

CONFIGURACIÓN | CONFIGURATION

INSTALACIÓN VERTICAL EN PARED | VERTICAL WALL INSTALLATION

Tipo | Type A (Standard)



Tipo | Type B



INSTALACIÓN HORIZONTAL EN EL TECHO | HORIZONTAL CEILING INSTALLATION

Tipo | Type A (Standard)

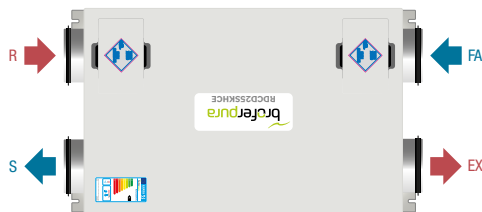

Tipo | Type A1 (Standard)

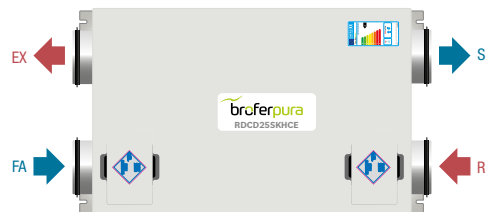

Tipo | Type B

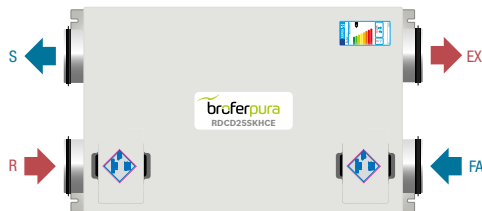

Tipo | Type B1

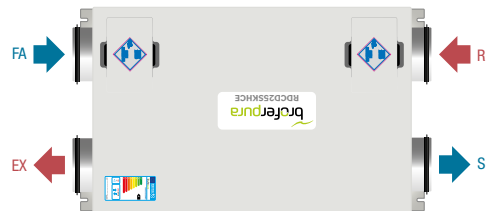

Leyenda | Legend

- EX = expulsión | exhaust air
- R = retorno | return
- FA = aire exterior | fresh air
- S = salida | supply



DECLARACIÓN DE RENDIMIENTO DE LA UNIDAD DE RECUPERACIÓN DEL CALOR
DECLARATION OF PERFORMANCE HEAT RECOVERY UNIT

Nombre o denominación comercial del fabricante Supplier name or trade mark	BROFER								
Identificador del modelo del proveedor y opciones instaladas Supplier Model Identifier and options installed	RDCD25SKHCE + 4BRF			RDCD25SKHCE + RHRF / CO2RF			RDCD25SKHCE + RHRF / CO2RF locali-local		
Clima de referencia Reference climate	Templado Temperate	Frío Cold	Cálido Hot	Templado Temperate	Frío Cold	Cálido Hot	Templado Temperate	Frío Cold	Cálido Hot
SEC en [kWh / (m ² a)] para cada tipo de clima (templado, cálido, frío) for each type of climate (temperate, hot, cold)	-30,22	-67,95	-8,61	-34,09	-73,19	-11,7	-38,63	-79,55	-15,19
SEC Class	B	A+	E	A	A+	E	A	A+	E
Tipo declarado de la unidad de ventilación Declared Typology	UVR-B bidireccional UVR-B Bidirectional			UVR-B bidireccional UVR-B Bidirectional			UVR-B bidireccional UVR-B Bidirectional		
Tipo de accionamiento instalado Type of drive installed	Accionamiento con varias velocidades Multi-speed drive			Velocidad variable Variable speed			Velocidad variable Variable speed		
Tipo de sistema de recuperación del calor Type of heat recovery	con recuperación Recuperative			con recuperación Recuperative			con recuperación Recuperative		
Eficiencia térmica ¹ Thermal efficiency ¹	70%			70%			70%		
Caudal máximo en [m ³ / h] ² Maximum flow rate in [m ³ /h] ²	220			220			220		
Potencia eléctrica total con caudal máximo [W] Maximum electric Power in [W]	114			114			114		
Nivel de potencia acústica (LWA) en [dB(A)] ³ Sound Power Level (LWA) in [dB(A)] ³	46			46			46		
Caudal de referencia en [m ³ / h] ⁴ Reference flow rate [m ³ /h] ⁴	154			154			154		
Diferencias de presión de referencia [Pa] Reference pressure difference in [Pa]	50			50			50		
SPI in [W/m ³ /h] ⁵	0,28			0,28			0,28		
Factor de control y tipología Control factor and typology	1			0,85			0,65		
Porcentaje máximo de fugas internas [%] ⁶ Declared maximum internal leakage [%] ⁶	0,7			0,7			0,7		
Porcentaje máximo de fugas externas [%] ⁶ Declared maximum external leakage [%] ⁶	1,5			1,5			1,5		
AHS (kWh de energía primaria / año) Internet address for pre/dis-assembly instruction	www.broferpura.it								





- 1: Eficiencia de acuerdo con EN13141-7:2010 del caudal de referencia a 50 Pa | Efficiency according EN13141-7:2010 at reference flow at 50 Pa
2: Caudal máximo a 100 Pa de presión externa | Maximum flow at 100 Pa external pressure
3: Emisión desde la caja hasta el caudal de referencia a 50 Pa de presión externa | Casing radiation at reference flow rate at 50 Pa external pressure
4: El porcentaje del caudal de referencia es del 70 % del caudal máximo a 50 Pa de presión externa de acuerdo con EN13141-7:2010
Reference flow rate is 70% of maximum flow at 50 Pa external pressure according EN13141-7:2010
5: De acuerdo con EN13141-7:2010 del caudal de referencia | According EN13141-7:2010 at reference flow rate
6: De acuerdo con EN13141-7:2010 | According EN13141-7:2010
SEC: Consumo de energía específico | Specific Energy Consumption

RDCD25SKHCE

CÓDIGOS | CODES

Modelo Model	Descripción Description
RDCD25SKHCE	
RDCD25SKHCEBE*	
KFTR060A	Kit de filtros de recambio (2 uds.) de eficiencia G4 Replacement filter kit (2 pcs) efficiency G4
FTRLET483	Filtro de recambio de eficiencia F7 Replacement filter efficiency F7

* Versión con batería eléctrica dentro de la unidad | Version with electric battery inside the unit.

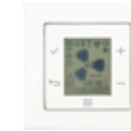
	4BRF	RHRF	CO2RF	MODBUSRF	APPRF	DSPRF
Modelo Model						
Control de la velocidad Speed control	●	●	●		●	●
By-pass	●	●	●		●	●
Anticongelante Defrost protection	●	●	●		●	●
Obstrucción de los filtros Clogged filters	●	●	●		●	●
Control de la humedad Humidity control		●				
Control del CO ₂ CO ₂ control			●			
Función de máxima potencia Booster function	●				●	●
Transmisor MODBUS MODBUS gate way				●	●	
Ajuste de la velocidad Speeds setting						●
ON/OFF						●
Alarmas puntuales Punctual alarms	●	●	●			●

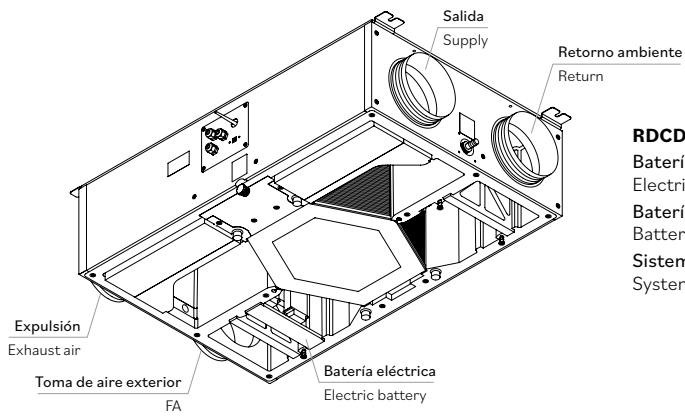

ACCESORIOS | ACCESSORIES**RDCD25SKCBE - RDCD25SKCEBE**

Batería eléctrica de 1 kw - 230 V - 50 Hz integrada en la unidad
Electric battery 1,5 kw - 230 V - 50 Hz integrated in the unit

Batería controlada por la PCB de la unidad
Battery controlled by PCB of the unit

Sistema no disponible después de la entrega de la unidad
System not available after unit delivery