

VMCS600

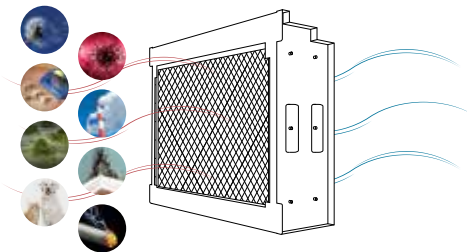

4BRF



Filtro elettronico (optional)
 efficienza UNI 11254 e PM 2,5 90/95%
 Electronic filter (optional)
 efficiency UNI 11254 and PM 2,5 90/95%

UNITÀ DECENTRALIZZATA VMC AD ALTISSIMA EFFICIENZA

Recuperatore di calore: scambiatore del tipo in controcorrente in materiale plastico ad altissima efficienza. Completo di bypass automatico e vasca raccolta condensa.

Struttura: a sandwich afonizzata autoportante. Provvista di pannelli asportabili per le operazioni di manutenzione ordinaria e straordinaria. Completa di staffe per il fissaggio a soffitto.

Ventilatori: centrifughi a doppia aspirazione con motore elettrico EC brushless direttamente accoppiato.

Filtri: efficienza G4 su ripresa ambiente. Efficienza M5 su presa aria esterna.

Optional:

- controllo CO₂ (CO2RF)
- filtro efficienza F7 (VMCS600 F7)
- modulo comunicazione modbus (MODBUSRF)

DECENTRALIZED VMC HEAT RECOVERY UNIT WITH VERY HIGH EFFICIENCY

Heat recovery: high efficiency plastic counter-current exchanger. Complete with automatic bypass and condensate collection basin.

Structure: self-supporting soundproof sandwich structure. Equipped with removable panels for ordinary and extraordinary maintenance operations. Complete with brackets for ceiling fixing.

Fans: double inlet centrifugal fans with directly coupled brushless EC electric motor.

Filters: G4 efficiency on return air. M5 efficiency on fresh air.

Optional:

- CO₂ control (CO2RF)
- F7 efficiency filter (VMCS600 F7)
- modbus communication device (MODBUSRF)

VMCS600 - VMCS600FE

Portata aria rinnovo Replacement airflow	600 mc/h
Portata aria estrazione Extraction airflow	600 mc/h
Efficienza recupero termico* Thermal recovery efficiency*	90 %
Potenza nominale singolo ventilatore (w) Installed power single fan (w)	156
Pressione sonora dB(A) Sound pressure dB(A)	38
Filtrazione aria rinnovo Replacement air filtration	M5 ISO COARSE ≥ 70 %
Filtrazione aria estrazione Extraction air filtration	G4 ISO COARSE ≥ 65 %
Filtrazione aria rinnovo (opzionale) Replacement air filtration (optional)	F7 ISO e PM1 ≥ 65 %
Filtrazione elettronica Electronic filtration	Opzionale Optional
Controllo CO ₂ CO ₂ control	Opzionale Optional

* (UNI EN 308) aria rinnovo: 5°C 72% UR / aria espulsione: 25°C 28% UR
 (UNI EN 308) fresh air: 5 ° C 72% RH / expulsion air: 25 ° C 28% RH



DISEGNI | DRAWINGS

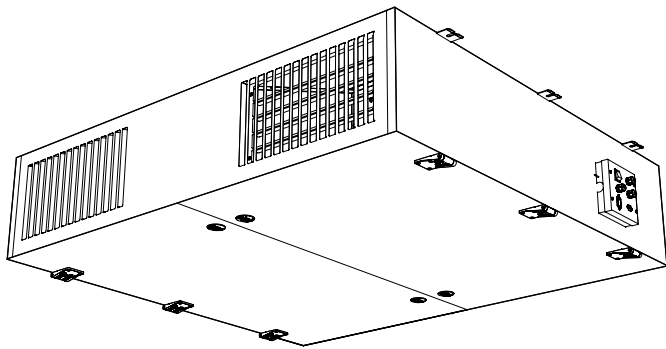

PESO | WEIGHT: 170 kg

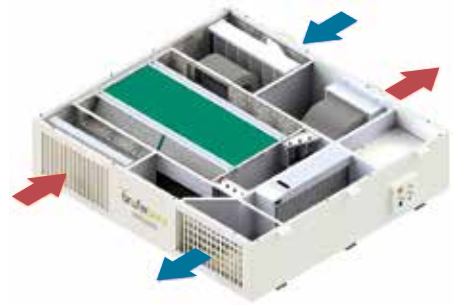

Vista dal basso | Bottom View

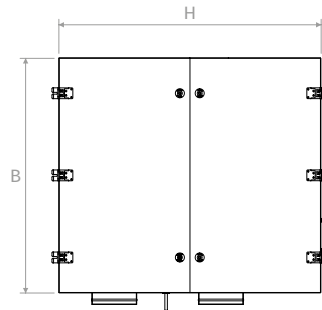

Vista laterale DX | Side view right

Vista frontale | front view

Vista laterale SX | Side view left

Vista posteriore | Rear view

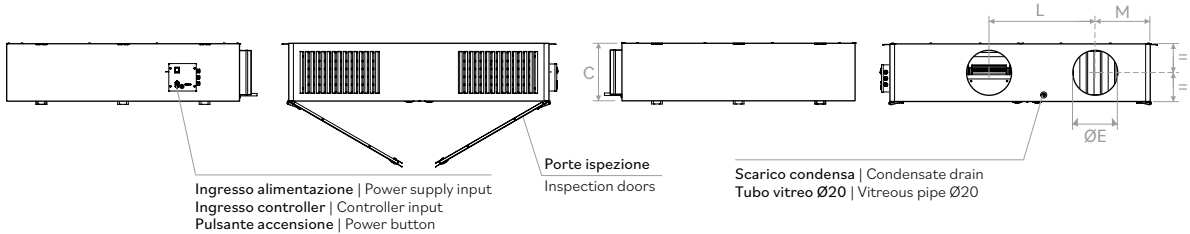

Vista dall'alto | Top view

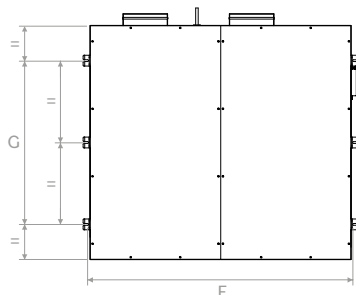

	B	H	C	ØE	F	G	L	M
mm	1300	1450	325	250	1478	910	591	307

DIAGRAMMI PRESTAZIONALI | PERFORMANCE CHARTS

SCAMBIATORE STANDARD CERTIFICATO EN 308 | STANDARD HEAT EXCHANGER EN 308 CERTIFIED

Diagramma efficienza estiva

Aria esterna: 32 °C / 50 % U.R.
 Aria ambiente: 26 °C / 50 % U.R.
Summer efficiency chart
 Fresh air: 32 °C / 50 % R.H.
 Return air: 26 °C / 50 % R.H.



Diagramma efficienza invernale

Aria esterna: - 5 °C / 80 % U.R.
 Aria ambiente: 20 °C / 50 % U.R.
Winter efficiency chart
 Fresh air: - 5 °C / 80 % R.H.
 Return air: 20 °C / 50 % R.H.

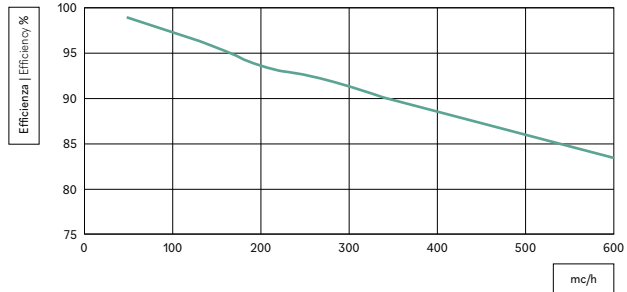
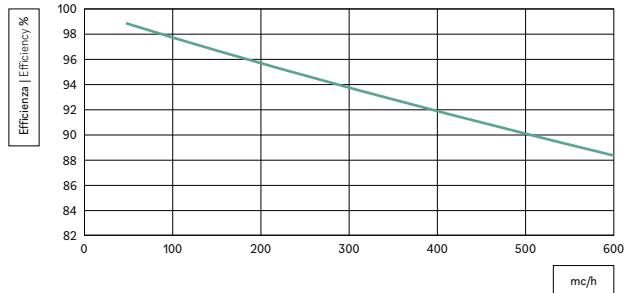

SCAMBIATORE ENTALPICO (efficienza su temperatura) | ENTHALPIC HEAT EXCHANGER (temperature efficiency)

Aria esterna: + 5 °C / 70 % U.R.
 Aria ambiente: 25°C / 50 % U.R.
 Fresh air: + 5 °C / 70 % R.H.
 Return air: 25°C / 50 % R.H.

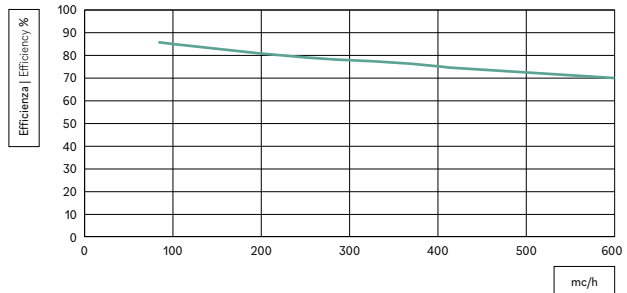

SCAMBIATORE ENTALPICO (efficienza su umidità) | ENTHALPIC HEAT EXCHANGER (humidity efficiency)

Aria esterna: + 5 °C / 70 % U.R.
 Aria ambiente: 25°C / 50 % U.R.
 Fresh air: + 5 °C / 70 % R.H.
 Return air: 25°C / 50 % R.H.

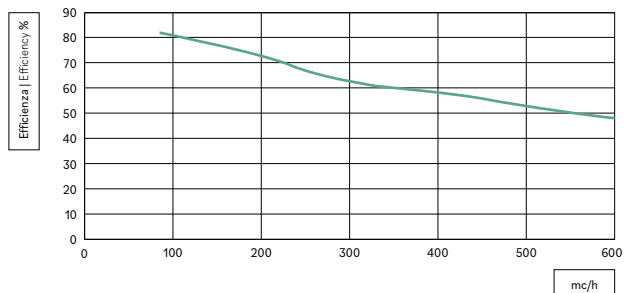

DATI ACUSTICI RELATIVI A POTENZA SONORA IRRAGGIATA DALLA STRUTTURA ACOUSTIC DATA RELATIVE TO THE SOUND POWER RADIATED BY THE CASING

	Portata aria	Frequenza Frequency								
	Air flow rate	Hz								
	mc/h	63	125	250	500	1000	2000	4000	8000	
Velocità alta High speed	600	40	51,5	52,5	52,5	54	53,5	44	31	dB
Velocità media Medium speed	470	36	46,5	46,5	44	49	46	36,5	27	dB
Velocità bassa Low speed	260	24	35,5	35	33	38,5	29,5	22	18	dB



CODICI | CODES

Modello Model	
VMCS600	versione standard standard version
VMCE600	versione con scambiatore entalpico version with enthalpic heat exchanger
VMCS600FE	versione con filtro elettronico version with electronic filter
VMCE600FE	versione con scambiatore entalpico e filtro elettronico version with enthalpic heat exchanger and electronic filter
VMCS600G4	filtro efficienza G4 (ricambio) filter G4 efficiency (spare part)
VMCS600M5	filtro efficienza M5 (ricambio) filter M5 efficiency (spare part)
VMCS600F7	filtro efficienza F7 per aria rinnovo F7 efficiency filter for replacement air

	4BRF	CO2RF	MODBUSRF
Modello Model			
Controllo velocità Speed control	●	●	
By-pass	●	●	
Antigelo Defrost protection	●	●	
Intasamento filtri Clogged filters	●	●	
Controllo umidità Humidity control			
Controllo CO ₂ CO ₂ control		●	
Funzione booster Booster function	●		
Trasmettitore MODBUS MODBUS gate way			●
Impostazione velocità Speeds setting			
ON/OFF			
Allarmi puntuali Punctual alarms	●	●	●



DATI ECODESIGN | ECODESIGN DATA SHET

Modello Model	Efficienza Efficiency	Portata aria nominale Nominal air flow rate	Pressione statica utile Useful static pressure	SFPInt	SFP-2018	Velocità frontale Front speed	Efficienza ventilatore Fan Efficiency	Leakage interno Internal leakage	Leakage esterno External leakage
	%	mc/h	pa	w/m ³ /s	w/m ³ /s	m/s	%	%	%
VMCS600	86,2	470	150	1512	1656	0,92	47,5	6,4	4,9

VMCS600

ACCESSORI | ACCESSORIES

Modello | Model

NMC160600		Modulo compatto di espulsione / presa aria di rinnovo in lamiera zincata verniciata RAL 9016 Compact module exhaust / fresh air galvanized steel RAL 9016 painted
RAVMCS600		Silenziatore circolare senza ogiva in lamiera zincata Circular sound attenuator with out ogive in galvanized steel
		RAVMCS600250 (250 mm)
		RAVMCS600500 (500 mm)
		RAVMCS600750 (750 mm)
		RAVMCS6001000 (1000 mm)

APPLICAZIONI | APPLICATIONS

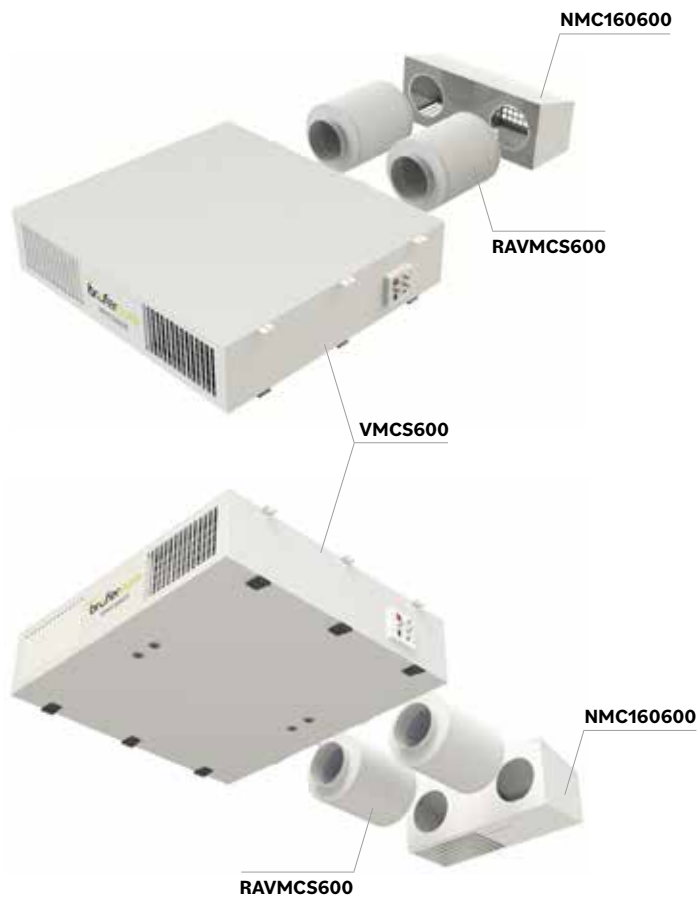

DISEGNI | DRAWINGS

NMC160600

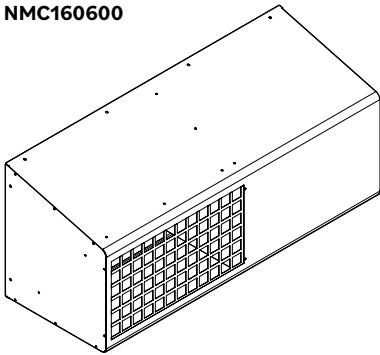

Vista dal basso | Bottom View

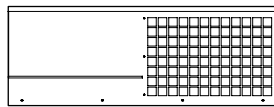

Vista frontale | Front View

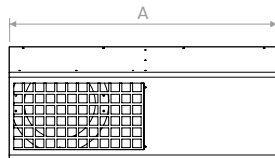

Vista laterale | Side View

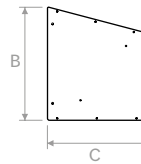

Vista posteriore | Rear View

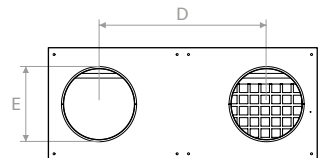

Vano di espulsione
Exhaust air compartment

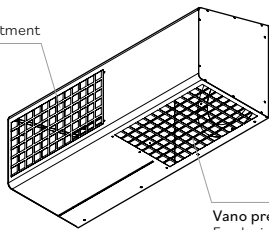

Vano presa aria esterna
Fresh air compartment

Canali di uscita del muro
Ducts coming out of the wall

Chigliottine per adattamento
circonferenza dei canali
Chillotines for circumference
adaption of the ducts

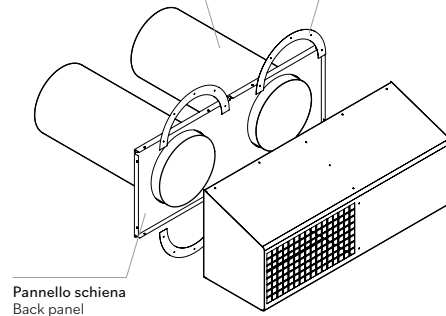

	A	B	C	D	E
mm	950	370	320	591	Ø 265

RAVMCS

Interno | Internal

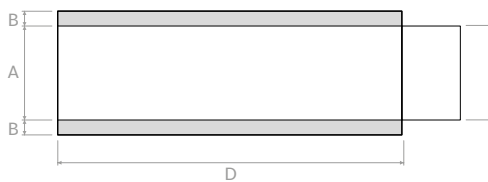

Esterno | External

	A	B	C	D
mm	250	25	248	250 / 500 / 750 / 1000