

RDCD25SK

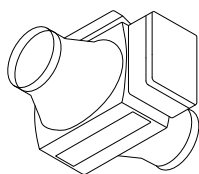

4BRF



Optional - ECOFILTRU PLUS

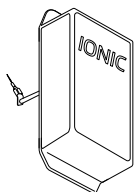

Optional - IONIC

UNITATE DE RECUPERARE CĂLDURĂ SISTEM CENTRALIZAT PENTRU UZ DOMESTIC, CU EFICIENȚĂ FOARTE RIDICATĂ INCLUSIV SISTEM DE CONTROL “PLUG AND PLAY”, WIRELESS BY-PASS AUTOMAT INCLUS INSTALARE ORIZONTALĂ-VERTICALĂ-DREAPTA -STÂNGA

Recuperare de căldură: schimbător de căldură în contracurent executat în întregime din material plastic.

Structură: corp autoportant din EPP, cu sistem acces filtre și racord condens.

Ventilator: plug fan cu motor EC fără perii, monoaspirant.

Filtre: unitățile sunt echipate cu filtre standard din material sintetic eficiență G4, opțional F7 pentru filtrul de aer proaspăt.

DOMESTIC CENTRALIZED HEAT RECOVERY UNIT WITH VERY HIGH EFFICIENCY AND WITH WIRELESS PLUG AND PLAY CONTROL SYSTEM INCLUDED AUTOMATIC BY-PASS INCLUDED INSTALLATION HORIZONTAL-VERTICAL-RIGHT -LEFT

Heat recovery: heat exchanger of the type in countercurrent entirely made of plastic material.

Structure: free standing EPP seal, complete of filters extraction system and drain condensate.

Fans: plug fan with EC Brushless engine single inlet.

Filters: the units are equipped with standard filter cells synthetic fiber efficiency G4, optional F7 efficiency on fresh air.

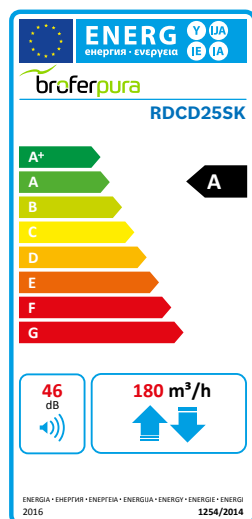

Debit de aer nominal (mc/h) Nominal air flow (mc/h)	180
Presiune statică utilă (Pa) Useful static pressure (pa)	100

CARACTERISTICI PENTRU FIECARE VENTILATOR | DATA FOR EACH FAN

Putere instalată (W) Installed power (W)	27
Turație (1/min) Round (1/MIN)	3700
Curent (A) Current (A)	0.27
Tensiune alimentare (V) Rated voltage (V)	230
Frecvență (Hz) Frequency (HZ)	50
Viteze (nr) Speed (nr)	3+(1 booster)

FILTRE | FILTERS

Eficiență Efficiency Standard	G4 ISO COARSE > 65 %
Eficiență Efficiency Optional	F7 ISO e PM1 > 65 %



DESENE | DRAWINGS

GREUTATE | WEIGHT: 14 kg

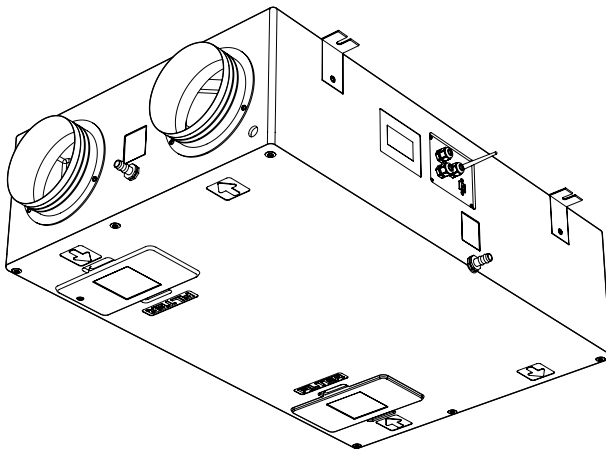

Vedere de jos | Bottom View

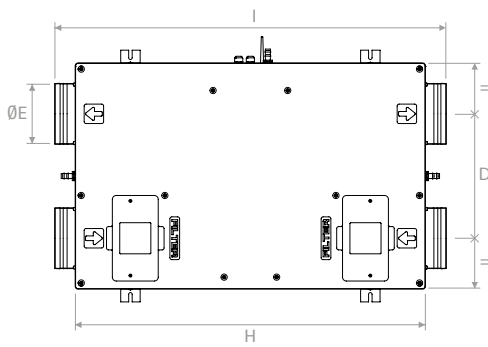

Vedere în interior | Internal view

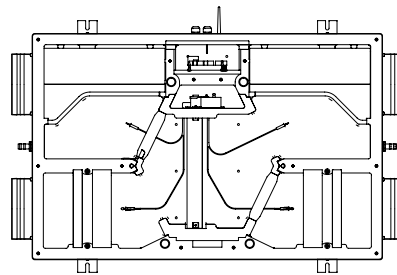

Vedere laterală | Side view

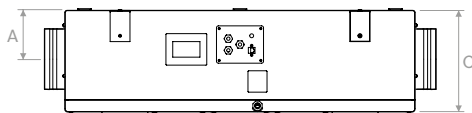

Vedere din față | Front view

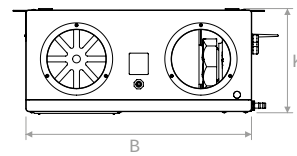

Vedere în plan | Plan view

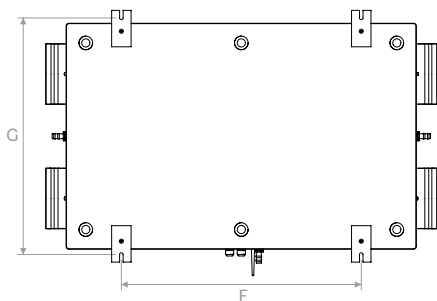

	A	B	C	D	ØE	F	G	H	I	K
mm	125	580	260	320	156	617	609	900	1005	268



PERFORMANȚĂ CERTIFICATĂ CONFORM EN 13141:7:2011 | PERFORMANCE EN 13141:7:2011 CERTIFIED

Presiune statică utilă
Useful static pressure
① ③

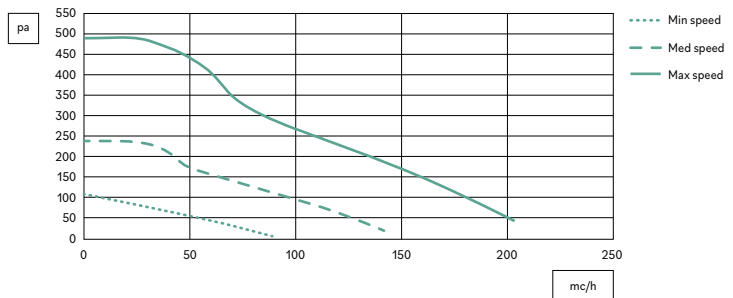

S.F.P.
②

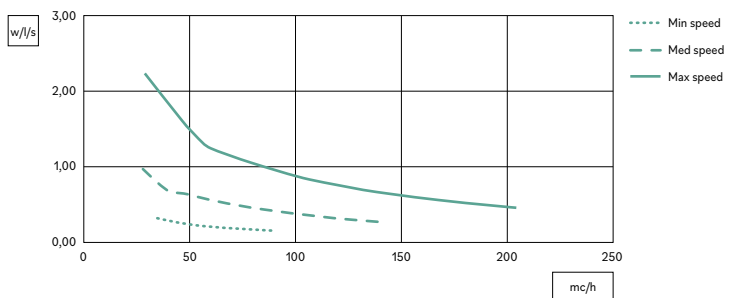

SCHIMBĂTOR DE CALDURĂ CERTIFICAT EN 308 | HEAT EXCHANGER EN 308 CERTIFIED

Diagramă eficiență vara
Aer proaspăt: 32 °C / 50 % R.H.
Aer evacuat: 26 °C / 50 % R.H.
Summer efficiency chart
Fresh air: 32 °C / 50 % R.H.
Return air: 26 °C / 50 % R.H.

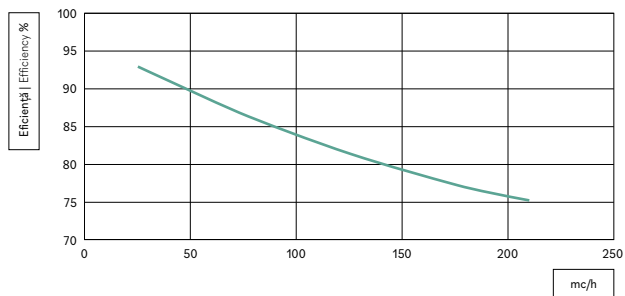

Diagramă eficiență iarna
Aer proaspăt: -5 °C / 80 % R.H.
Aer evacuat: 20 °C / 50 % R.H.
Winter efficiency chart
Fresh air: -5 °C / 80 % R.H.
Return air: 20 °C / 50 % R.H.

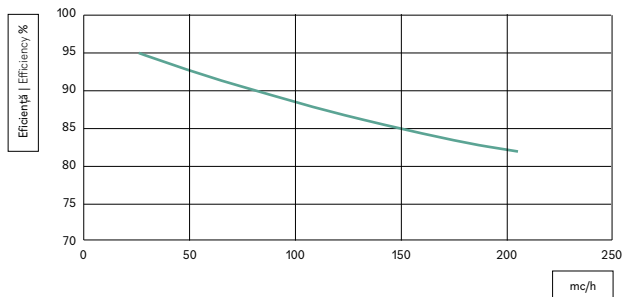

① Date cu filtru standard G4 | Data with standard G4 filters
② Date pentru un singur ventilator | Data for single fan
③ Pierdere de presiune aer cu filtru eficiență F7, 80 Pa la debit maxim cu filtrul curat
Air pressure drop with F7 efficiency filter 80 pa at maximum air flow rate with clean filter



CONFIGURAȚIE | CONFIGURATION

INSTALARE VERTICALĂ LA PERETE | VERTICAL WALL INSTALLATION

Tip | Type A (Standard)

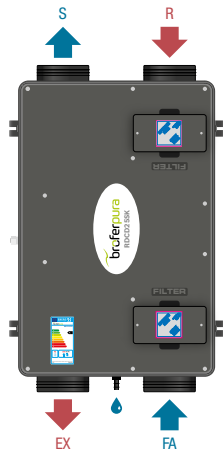

Tip | Type B

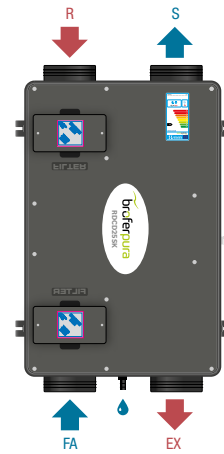

INSTALARE ORIZONTALĂ LA PLAFON | HORIZONTAL CEILING INSTALLATION

Tip | Type A (Standard)

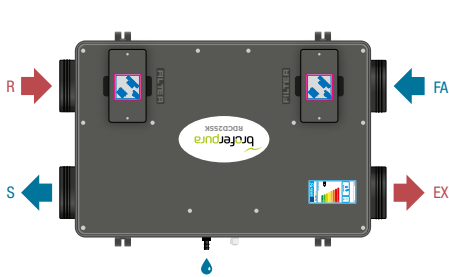

Tip | Type A1 (Standard)

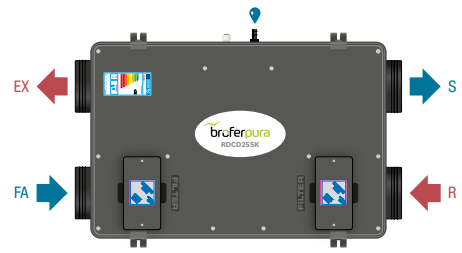

Tip | Type B



Tip | Type B1

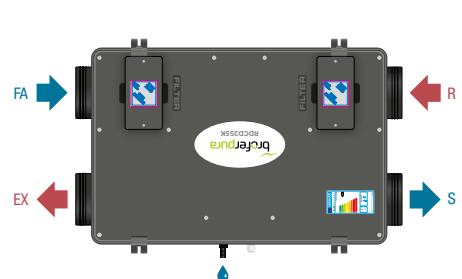

- Legendă | Legend**
 EX = aer evacuat | exhaust air
 R = raspirat | return
 FA = aer proaspăt | fresh air
 S = introdus | supply



DECLARAȚIE DE PERFORMANȚĂ A UNITĂȚII DE RECUPERARE CĂLDURĂ

DECLARATION OF PERFORMANCE HEAT RECOVERY UNIT

Nume fabricant sau denumire comercială Supplier name or trade mark	BROFER								
Codul furnizorului și accesoriile instalate Supplier Model Identifier and options installed	RDCD25SK + 4BRF			RDCD25SK + RHRF / CO2RF			RDCD25SK + RHRF / CO2RF local-local		
Climat de referință Reference climate	Temperat Temperate	Rece Cold	Cald Hot	Temperat Temperate	Rece Cold	Cald Hot	Temperat Temperate	Rece Cold	Cald Hot
SEC in [kWh/(m ² a)] pentru fiecare tip de climat (temperat, cald, rece) for each type of climate (temperate, hot, cold)	-35,83	-76,93	-12,92	-38,59	-80,56	-14,55	-41,80	-84,92	-17,10
SEC Class	A	A+	E	A	A+	E	A	A+	E
Tipologie declarată Declared Typology	UVR-B Bidirecțional UVR-B Bidirectional			UVR-B Bidirecțional UVR-B Bidirectional			UVR-B Bidirecțional UVR-B Bidirectional		
Tipul de ventilator instalat Type of drive installed	Ventilator cu mai multe viteze Multi-speed drive			Viteză variabilă Variable speed			Viteză variabilă Variable speed		
Tipul de recuperare de căldură Type of heat recovery	Recuperativ Recuperative			Recuperativ Recuperative			Recuperativ Recuperative		
Eficiență termică ¹ Thermal efficiency ¹	81,1%			81,1%			81,1%		
Debit maxim de aer [m ³ /h] ² Maximum flow rate in [m ³ /h] ²	180			180			180		
Putere maximă [W] Maximum electric Power in [W]	60			60			60		
Nivel putere sonoră (LWA) în [dB(A)] ³ Sound Power Level (LWA) in [dB(A)] ³	46			46			46		
Debit de referință [m ³ /h] ⁴ Reference flow rate [m ³ /h] ⁴	126			126			126		
Presiune de referință în [Pa] Reference pressure difference in [Pa]	50			50			50		
SPI in [W/m ³ /h] ⁵	0,21			0,21			0,21		
Factor de control și tipologie Control factor and typology	1			0,85			0,65		
Grad de neetanșitate internă maximă declarată [%] ⁶ Declared maximum internal leakage [%] ⁶	1,2			1,2			1,2		
Grad de neetanșitate exterioară maximă declarată [%] ⁶ Declared maximum external leakage [%] ⁶	2,5			2,5			2,5		
SEC - Climă temperată - (kWh electricitate/an) SEC Tempertate climate (kWh electricity/annum)	308			235			156		
AHS (kWh energie primară/an) AHS (kWh primary energy/annum)	4.298	8.409	1.944	4.389	8.585	1.985	4.509	8.821	2.039
Adresa Web pentru instrucțiuni de folosire Internet address for pre/dis-assembly instruction	www.broferpura.it								

1: Eficiență conform EN13141-7:2010 la debitul nominal și 50 Pa | Efficiency according EN13141-7:2010 at reference flow at 50 Pa
2: Debit maxim la presiune externă 100 Pa | Maximum flow at 100 Pa external pressure
3: Zgomot radiat de carcasa la debitul nominal și presiune externă 50 Pa | Casing radiation at reference flow rate at 50 Pa external pressure
4: Debitul de referință este 70% din debitul maxim la 50 Pa presiune externă, conform EN13141-7:2010
Reference flow rate is 70% of maximum flow at 50 Pa external pressure according EN13141-7:2010
5: Conform EN13141-7:2010 la debitul nominal | According EN13141-7:2010 at reference flow rate
6: Conform EN13141-7:2010 | According EN13141-7:2010
SEC: CConsum specific de energie | Specific Energy Consumption







PREȚURI | PRICES

Model Model	Descriere Description	€
RDCD25SK		
RDCD25SKI**	Dimensiuni Sizes pag. 266	
RDCD25SKBE***		
KFTR060A	Kit filtru de schimb (2 buc) eficiență G4 Replacement filter kit (2 pcs) efficiency G4	
FTRLET483	Filtru de schimb eficiență F7 Replacement filter efficiency F7	

* Versiune completă cu ionizator IONIC | Version complete with IONIC ionizer

** Versiune cu baterie electrică în interiorul unității | Version with electric battery inside the unit

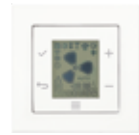
	4BRF	RHRF	CO2RF	MODBUSRF	APPRF	DSPRF
Model Model						
Control viteze Speed control	●	●	●		●	●
By-pass	●	●	●		●	●
Protecție îngheț Defrost protection	●	●	●		●	●
Filtre colmate Clogged filters	●	●	●		●	●
Control umiditate Humidity control		●				
Control CO ₂ CO ₂ control			●			
Funcție booster Booster function	●				●	●
Ieșire MODBUS MODBUS gate way				●	●	
Selectare viteze Speeds setting						●
ON/OFF						●
Alarmer punctuale Punctual alarms	●	●	●			●

€ inclus în preț
 included in the price

ACCESORII | ACCESSORIES

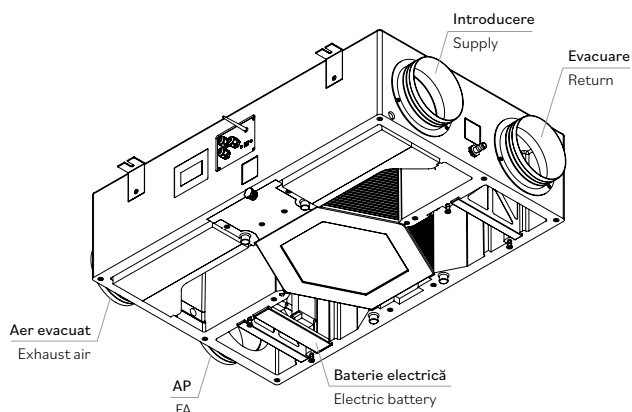

RDCD25SKBE - RDCD25SKEBE

Baterie electrică 1 kw - 230 V - 50 Hz integrată în unitate
Electric battery 1 kw - 230 V - 50 Hz integrated in the unit

Baterie controlată de modulul PCB al unității
Battery controlled by PCB of the unit

Sistem indisponibil după livrarea unității
System not available after unit delivery

EHRDCD25SK

MODUL ÎNCASTRARE RECUPERATOR ÎN PERETE | UNIT MODULE BUILT-IN THE WALL

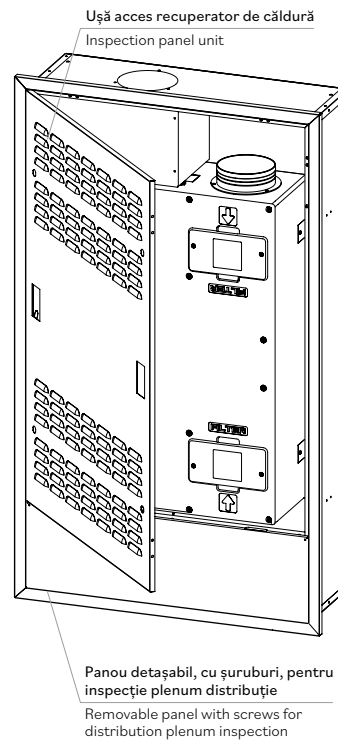

Modul de încastrare a recuperatorului în perete, din oțel galvanizat (vopsea RAL 9003 mată la cerere) cu izolație termică la interior. Conceput pentru recuperator RDCD25SKE Unitate în configurație B.

- Nu necesită instalarea unui sistem de evacuare condens.
- Instalare punct de evacuare și în partea de sus și în partea de jos.
- Poziționare plenum de distribuție (introducere și evacuare) și în partea superioară și în partea inferioară.
- Poziționare plenum de distribuție (introducere și evacuare) axial și perpendicular pe peretele cutiei.
- Deschidere ușă de acces la stânga, la dreapta sau pe dedesupt, funcție de necesități în timpul instalării.

External housing module to be embedded in the wall made of galvanized steel (painted RAL 9003 on request) with internal thermal insulation. Suitable for installation of RDCD25SKE (unit in "B" orientation).

- It does not require the installation of a condensate drainage system.
- Installation of the air exhaust point in both the upper and lower part.
- Positioning of the distribution plenum (supply and return) both in upper and lower part.
- Positioning of the distribution plenum (supply and return) both axial and perpendicular to the housing wall.
- Opening of the door to the left, to the right or recessed modifiable during installation.



DESENE | DRAWINGS

Vedere de jos | Bottom view

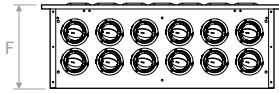

Vedere din față | Front view

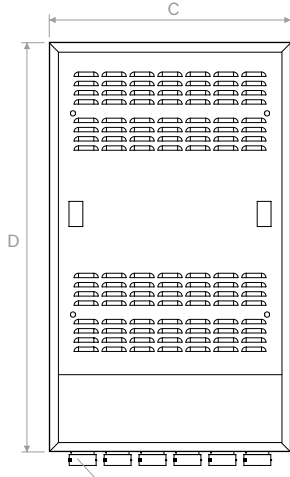

Vedere laterală | Lateral view

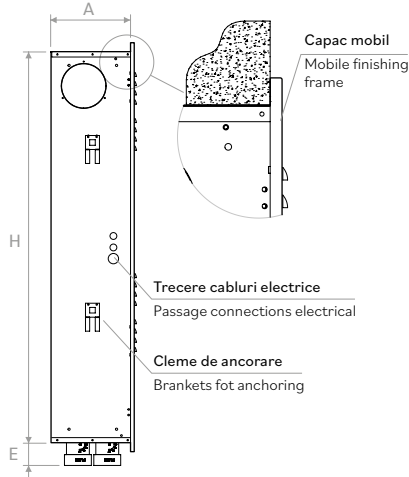

Vedere de sus | Top view

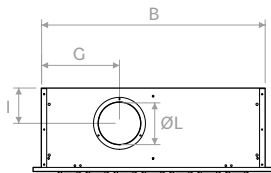

SOLUȚII DE DESCHIDERE A PANOULUI ÎN TIMPUL MONTAJULUI
SOLUTIONS FOR OPENING PANELS DURING ASSEMBLY

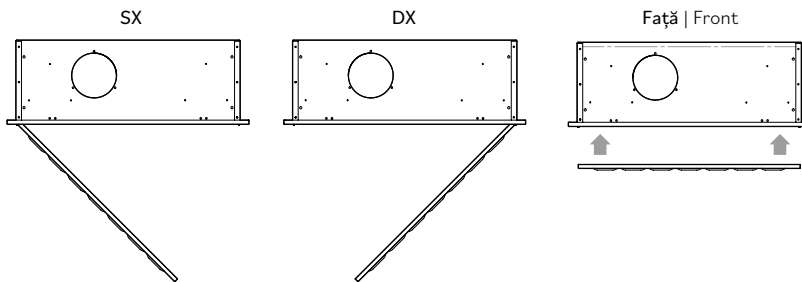

	A	B	C	D	E	F	G	H	I	ØL
mm	285	800	865	1465	80	300	279	1400	126	160

CONFIGURAȚII POSIBILE
POSSIBLE CONFIGURATIONS

Poziție racord evacuare
Exhaust air duct position

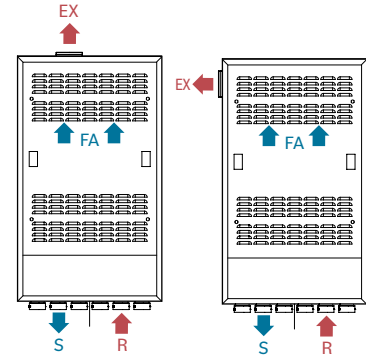

Orientare unitate
Unit orientation

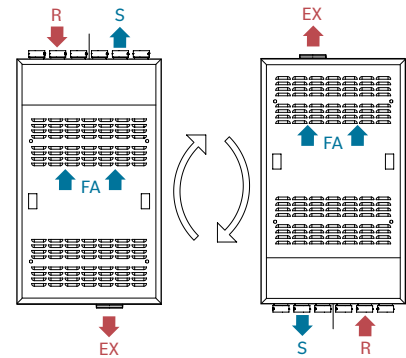

Poziționare racorduri introducere/evacuare
Spigots position supply/return

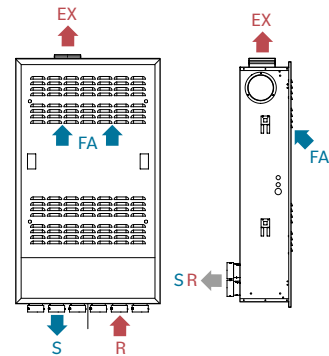

Legendă | Legend

- EX = aer evacuat | exhaust air
- R = aspirat | return
- FA = aer proaspăt | fresh air
- S = introdus | supply

PREȚURI | PRICES

Model | Model €

EHRDCD25SK

EHRDCD25SK9003*

* Versiune RAL 9003 culoare mat | Version RAL 9003 matt painted



EHCRDCD25SK

CUTIE MONTAJ ÎNCASTRAT ÎN PERETE | HOUSING UNIT MODULE FLUSH WITH THE WALL

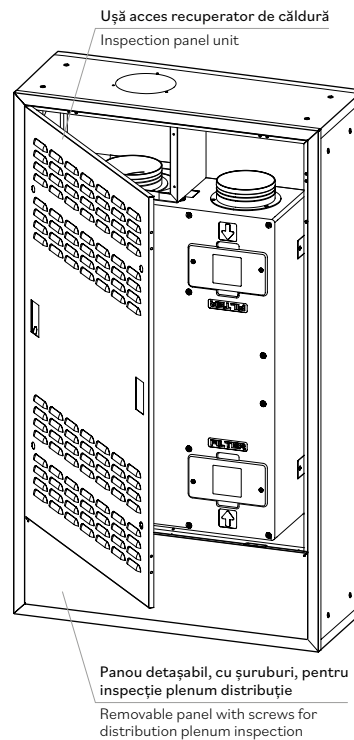

Cutie pentru încastrat recuperator în perete confecționată din oțel galvanizat (vopsea RAL 9003 mată, la cerere) cu izolație termică interioară, și cu carcasa exterioră din oțel galvanizat cu izolație termică din vată minerală de 30 mm între cele 2 carcase metalice. Corespunzătoare pentru instalarea recuperatoului model RDCD25SKE (Unitate în configurație B).

- Nu necesită instalarea unui sistem de evacuare condens.
- Se poate instala racordul de evacuare și în partea superioară și în partea inferioară.
- Poziționare plenum de distribuție (introducere și evacuare) și în partea superioară și în partea inferioară.
- Poziționare plenum de distribuție (introducere și evacuare) perpendicular pe peretele cutiei.
- Deschidere ușă de acces la stânga, la dreapta sau pe dedesupt, funcție de necesități în timpul instalării.

External housing module flush with the wall made of galvanized steel (painted RAL 9003 matt on request) with internal thermal insulation and additional external casing in galvanized steel with 30 mm thick mineral wool interposition. Suitable for installation of RDCD25SKE (unit in "B" orientation).

- It does not require the installation of a condensate drainage system.
- Installation of the air exhaust point in both upper and lower part.
- Positioning of the distribution plenum (supply and return) both in the upper and lower part.
- Positioning of the distribution plenum (supply and return) perpendicular to the housing wall.
- Opening of the door to the left, to the right or recessed modifiable during installation.



DESENE | DRAWINGS

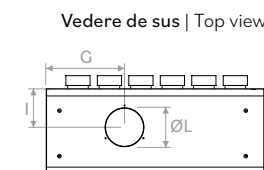
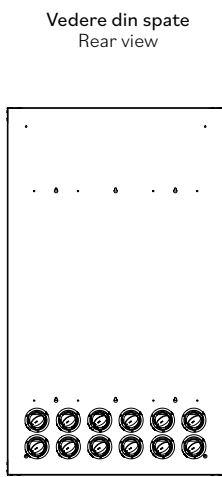
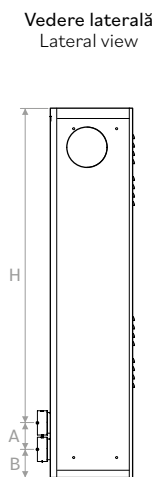
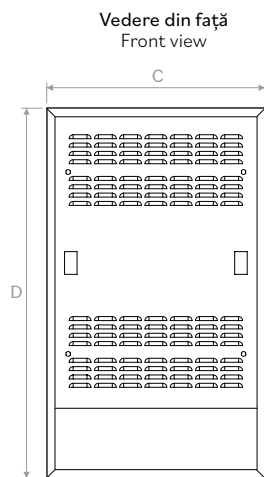
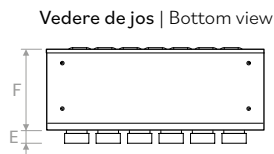

**CONFIGURAȚII POSIBILE
POSSIBLE CONFIGURATIONS**

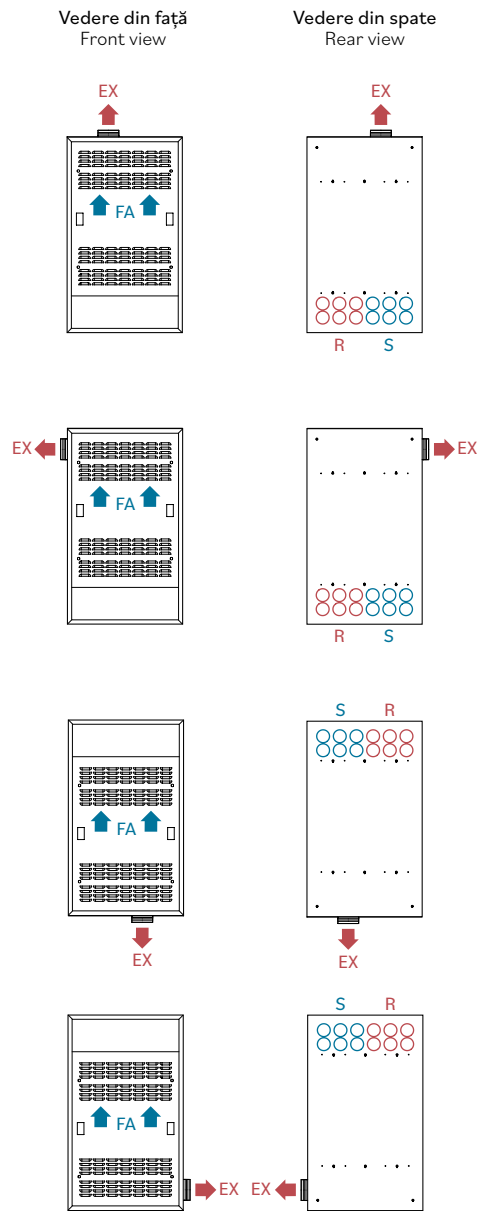

**SOLUȚII DE DESCHIDERE A PANOUȚII ÎN TIMPUL MONTAJULUI
SOLUTIONS FOR OPENING PANELS DURING ASSEMBLY**

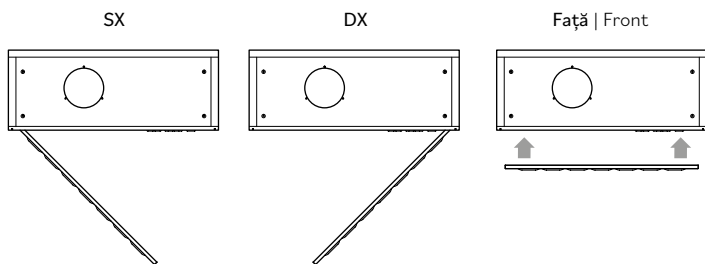

	A	B	C	D	E	F	G	H	I	ØL
mm	105	114	865	1465	51	330	310	1246	156	160

Legendă | Legend
 EX = aer evacuat | exhaust air
 R = aspirat | return
 FA = aer proaspăt | fresh air
 S = introdus | supply

PREȚURI | PRICES

Model Model	€
EHCRDCD25SK	
EHCRDCD25SK9003*	

* Versiune RAL 9003 culoare mat | Version RAL 9003 matt painted

