

RDCD25SKHCE

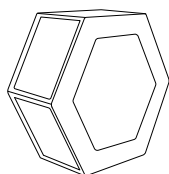

4BRF



Inclus - Schimbător de entalpie
Included - Enthalpic heat exchanger

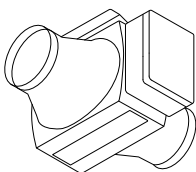

Optional - ECOFILTRU PLUS

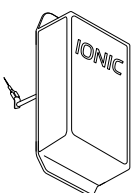

Optional - IONIC

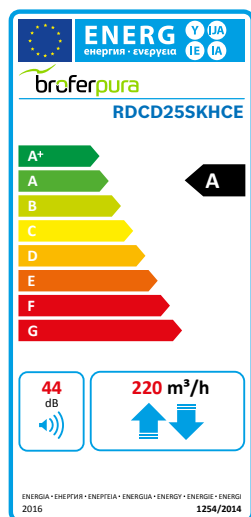

UNITATE DE RECUPERARE CĂLDURĂ SISTEM CENTRALIZAT PENTRU UZ DOMESTIC, CU EFICIENȚĂ FOARTE RIDICATĂ INCLUSIV SISTEM DE CONTROL “PLUG AND PLAY”, WIRELESS BY-PASS AUTOMAT INCLUS INSTALARE ORIZONTALĂ-VERTICALĂ-DREAPTA - STÂNGA

Recuperare de căldură: schimbător de căldură în contracurent executat în întregime din material plastic. *Versiune cu schimbător de căldură entalpic.*

Structură: corp autoportant din EPP, cu sistem acces filtre. Carcasă exterioară izolată fonic executată din oțel vopsit.

Ventilator: plug fan cu motor EC fără perii, monoaspirant.

Filtre: unitățile sunt echipate cu filtre standard din material sintetic eficiență G4, opțional F7 pentru filtrul de aer proaspăt.

DOMESTIC CENTRALIZED HEAT RECOVERY UNIT WITH VERY HIGH EFFICIENCY AND WITH WIRELESS PLUG AND PLAY CONTROL SYSTEM INCLUDED AUTOMATIC BY-PASS INCLUDED INSTALLATION HORIZONTAL-VERTICAL-RIGHT -LEFT

Heat recovery: heat exchanger of the type in countercurrent entirely made of plastic material. *Version with enthalpic heat exchanger.*

Structure: free standing EPP seal, complete of filters ex traction system. External casing made by prepainted steel with sound proof insulation.

Fans: plug fan with EC Brushless engine single inlet.

Filters: the units are equipped with standard filter cells synthetic fiber efficiency G4, optional F7 efficiency on fresh air.

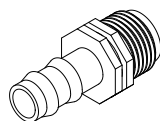

Predispoziție pentru uscare prin condensare.
Predisposition for condensate drying.

Debit de aer nominal (mc/h) Nominal air flow (mc/h)	220
Presiune statică utilă (Pa) Useful static pressure (pa)	100

CARACTERISTICI PENTRU FIECARE VENTILATOR | DATA FOR EACH FAN

Putere instalată (W) Installed power (W)	50
Turație (1/min) Round (1/MIN)	4320
Curent (A) Current (A)	0,46
Tensiune alimentare (V) Rated voltage (V)	230
Frecvență (HZ) Frequency (HZ)	50
Viteze (nr) Speed (nr)	3+(1 booster)

FILTRE | FILTERS

Eficiență Efficiency Standard	G4 ISO COARSE > 65 %
Eficiență Efficiency Optional	F7 ISO e PM1 > 65 %



DESENE | DRAWINGS

GREUTATE | WEIGHT: 30 kg

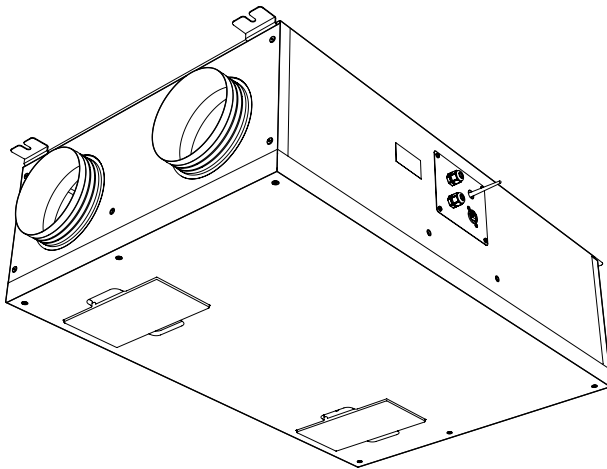

Vedere de jos | Bottom View

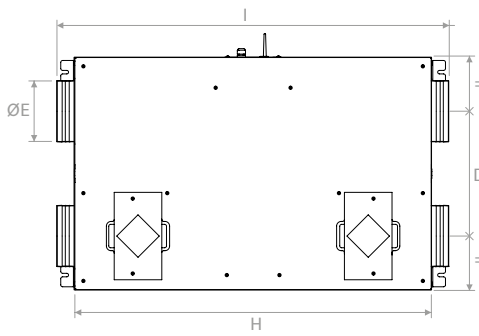

Vedere în interior | Internal view

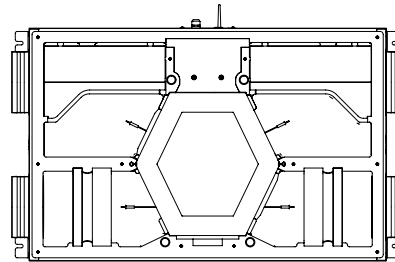

Vedere laterală | Side view

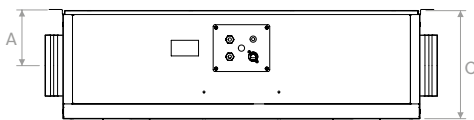

Vedere din față | Front view

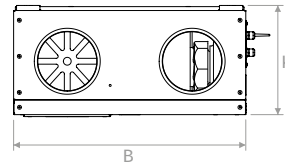

Vedere în plan | Plan view

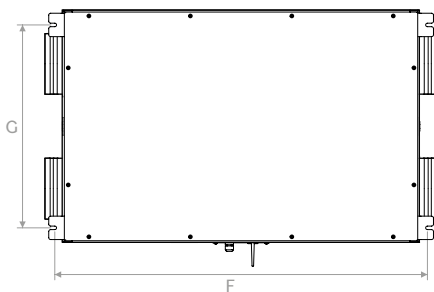

	A	B	C	D	ØE	F	G	H	I	K
mm	135	595	277	320	156	955	520	914	1005	282



PERFORMANȚĂ CERTIFICATĂ CONFORM EN 13141:7:2011 | PERFORMANCE EN 13141:7:2011 CERTIFIED

Presiune statică utilă
Useful static pressure
① ③

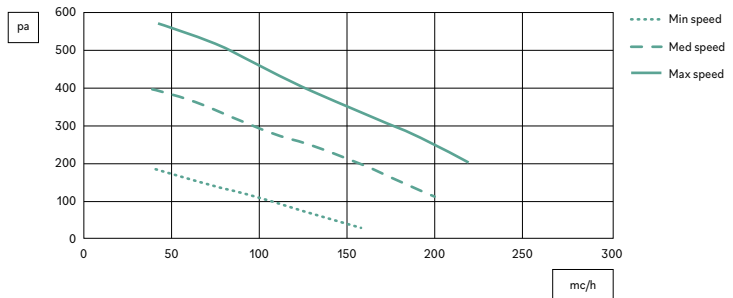

S.F.P.
②

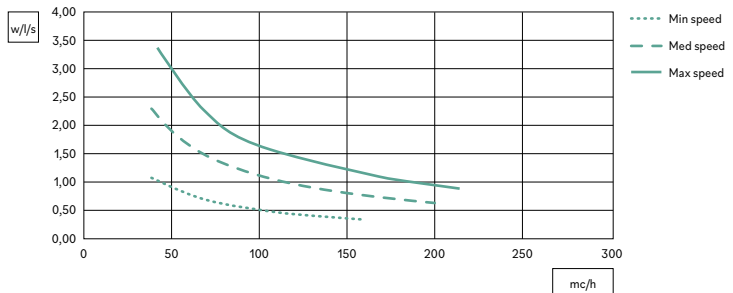

Diagramă eficiență căldură sensibilă iarna
Aer proaspăt: 25 °C
Aer evacuat: 5 °C
Winter sensible efficiency chart
Fresh air: 25 °C
Return air: 5 °C

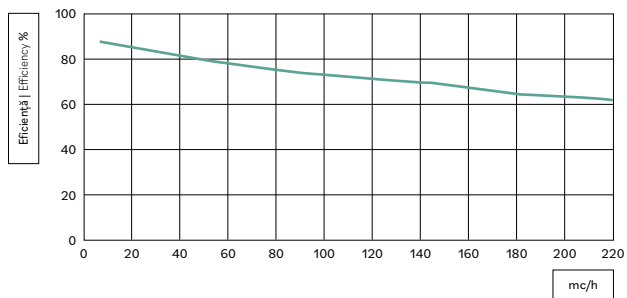

Diagramă eficiență căldură latentă iarna
Aer proaspăt: 5 °C - 79 % U.R.
Aer evacuat: 25 °C - 50 % U.R.
Winter latent efficiency chart
Fresh air: 5 °C - 79 % R.H.
Return air: 25 °C - 50 % R.H.

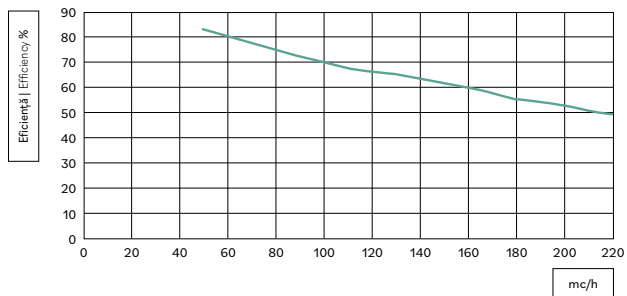

① Date cu filtru standard G4 | Data with standard G4 filters
 ② Date pentru un singur ventilator | Data for single fan
 ③ Pierdere de presiune aer cu filtru eficiență F7, 80 Pa la debit maxim cu filtrul curat
 Air pressure drop with F7 efficiency filter 80 Pa at maximum air flow rate with clean filter



Diagramă eficiență căldură sensibilă vara
Summer sensible efficiency chart
 Aer proaspăt: 35 °C
 Aer evacuat: 25 °C
 Fresh air: 35 °C
 Return air: 25 °C

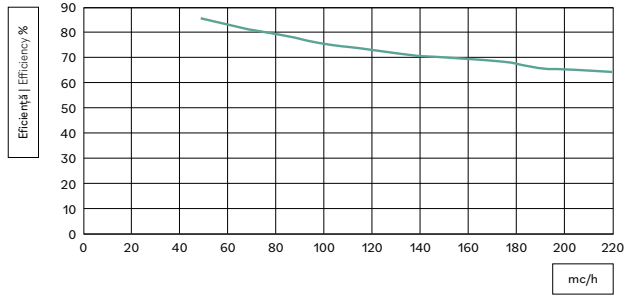

Diagramă eficiență căldură latentă vara
Summer latent efficiency chart
 Aer proaspăt: 35 °C - 57 % U.R.
 Aer evacuat: 25 °C - 50 % U.R.
 Fresh air: 35 °C - 57 % R.H.
 Return air: 25 °C - 50 % R.H.

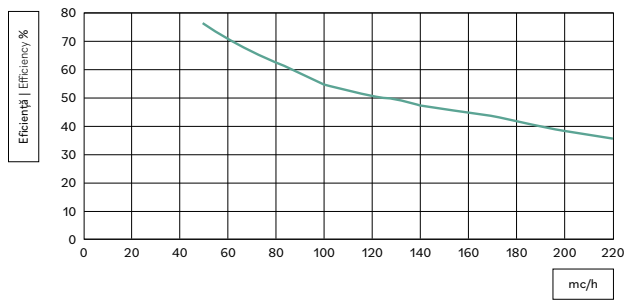

RDCD25SKHCE

CONFIGURAȚIE | CONFIGURATION

INSTALARE VERTICALĂ LA PERETE | VERTICAL WALL INSTALLATION

Tip | Type A (Standard)



Tip | Type B



INSTALARE ORIZONTALĂ LA PLAFON | HORIZONTAL CEILING INSTALLATION

Tip | Type A (Standard)

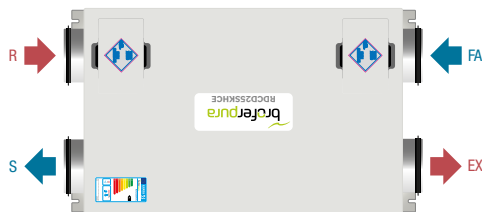

Tip | Type A1 (Standard)

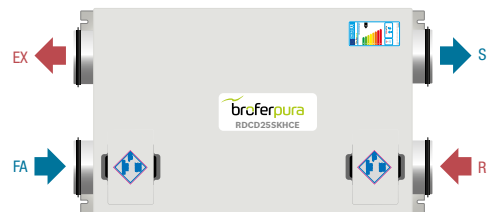

Tip | Type B

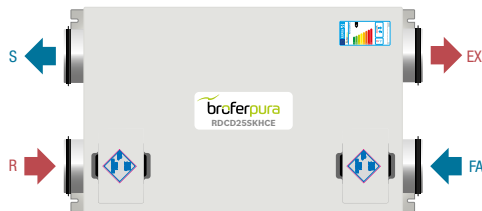

Tip | Type B1

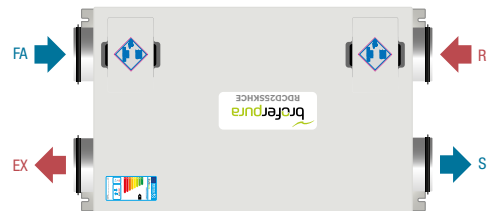

Legendă | Legend

- EX = aer evacuat | exhaust air
- R = raspirat | return
- FA = aer proaspăt | fresh air
- S = introdus | supply



DECLARAȚIE DE PERFORMANȚĂ A UNITĂȚII DE RECUPERARE CĂLDURĂ

DECLARATION OF PERFORMANCE HEAT RECOVERY UNIT

Nume fabricant sau denumire comercială Supplier name or trade mark	BROFER								
Codul furnizorului și accesoriile instalate Supplier Model Identifier and options installed	RDCD25SKHCE + 4BRF			RDCD25SKHCE + RHRF / CO2RF			RDCD25SKHCE + RHRF / CO2RF local-local		
Climat de referință Reference climate	Temperat Temperate	Rece Cold	Cald Hot	Temperat Temperate	Rece Cold	Cald Hot	Temperat Temperate	Rece Cold	Cald Hot
SEC in [kWh/(m ² a)] pentru fiecare tip de climat (temperat, cald, rece) for each type of climate (temperate, hot, cold)	-30,22	-67,95	-8,61	-34,09	-73,19	-11,7	-38,63	-79,55	-15,19
SEC Class	B	A+	E	A	A+	E	A	A+	E
Tipologie declarată Declared Typology	UVR-B Bidirecțional UVR-B Bidirectional			UVR-B Bidirecțional UVR-B Bidirectional			UVR-B Bidirecțional UVR-B Bidirectional		
Tipul de ventilator instalat Type of drive installed	Ventilator cu mai multe viteze Multi-speed drive			Viteză variabilă Variable speed			Viteză variabilă Variable speed		
Tipul de recuperare de căldură Type of heat recovery	Recuperativ Recuperative			Recuperativ Recuperative			Recuperativ Recuperative		
Eficiență termică ¹ Thermal efficiency ¹	70%			70%			70%		
Debit maxim de aer [m ³ /h] ² Maximum flow rate in [m ³ /h] ²	220			220			220		
Putere maximă [W] Maximum electric Power in [W]	114			114			114		
Nivel putere sonoră (LWA) în [dB(A)] ³ Sound Power Level (LWA) in [dB(A)] ³	46			46			46		
Debit de referință [m ³ /h] ⁴ Reference flow rate [m ³ /h] ⁴	154			154			154		
Presiune de referință în [Pa] Reference pressure difference in [Pa]	50			50			50		
SPI in [W/m ³ /h] ⁵	0,28			0,28			0,28		
Factor de control și tipologie Control factor and typology	1			0,85			0,65		
Grad de neetanșitate internă maximă declarată [%] ⁶ Declared maximum internal leakage [%] ⁶	0,7			0,7			0,7		
Grad de neetanșitate exterioară maximă declarată [%] ⁶ Declared maximum external leakage [%] ⁶	1,5			1,5			1,5		
Adresa Web pentru instrucțiuni de folosire Internet address for pre/dis-assembly instruction	www.broferpura.it								

- 1: Eficiență conform EN13141-7:2010 la debitul nominal și 50 Pa | Efficiency according EN13141-7:2010 at reference flow at 50 Pa
2: Debit maxim la presiune externă 100 Pa | Maximum flow at 100 Pa external pressure
3: Zgomot radiat de carcasa la debitul nominal și presiune externă 50 Pa | Casing radiation at reference flow rate at 50 Pa external pressure
4: Debitul de referință este 70% din debitul maxim la 50 Pa presiune externă, conform EN13141-7:2010
Reference flow rate is 70% of maximum flow at 50 Pa external pressure according EN13141-7:2010
5: Conform EN13141-7:2010 la debitul nominal | According EN13141-7:2010 at reference flow rate
6: Conform EN13141-7:2010 | According EN13141-7:2010
SEC: CConsum specific de energie | Specific Energy Consumption









RDCD25SKHCE

PREȚURI | PRICES

Model Model	Descriere Description	€
RDCD25SKHCE		
RDCD25SKHCBE*		
KFTR060A	Kit filtru de schimb (2 buc) eficiență G4 Replacement filter kit (2 pcs) efficiency G4	
FTRLET483	Filtru de schimb eficiență F7 Replacement filter efficiency F7	

* Versiune cu baterie electrică în interiorul unității | Version with electric battery inside the unit.

	4BRF	RHRF	CO2RF	MODBUSRF	APPRF	DSPRF
Model Model						
Control viteze Speed control	●	●	●		●	●
By-pass	●	●	●		●	●
Protecție îngheț Defrost protection	●	●	●		●	●
Filtre colmatate Clogged filters	●	●	●		●	●
Control umiditate Humidity control		●				
Control CO ₂ CO ₂ control			●			
Funcție booster Booster function	●				●	●
Ieșire MODBUS MODBUS gate way				●	●	
Selectare viteze Speeds setting						●
ON/OFF						●
Alarmer punctuale Punctual alarms	●	●	●			●
€	inclus în preț included in the price					



ACCESORII | ACCESSORIES

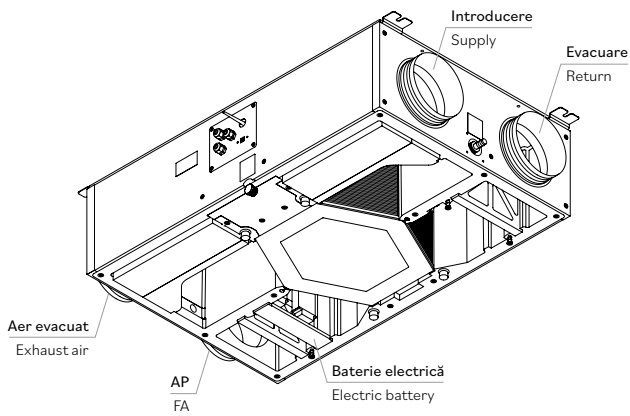

RDCD25SKCBE - RDCD25SKCEBE

Baterie electrică 1,5 kw - 230 V - 50 Hz integrată în unitate
 Electric battery 1,5 kw - 230 V - 50 Hz integrated in the unit

Baterie controlată de modulul PCB al unității
 Battery controlled by PCB of the unit

Sistem indisponibil după livrarea unității
 System not available after unit delivery

